

Operating Manual

for

Liconic Kiwi

Stores

SAB_V0011_MANUAL

Important Notice

© 2016, 2024 LiCONiC AG Liechtenstein, all rights reserved.

The Information contained in this document is subject to change without notice.

Information provided by LiCONiC AG is believed to be accurate and reliable. However, the user is responsible for the proper and correct use of the product. No license is granted by acquisition of the product for any patent or patent rights of LiCONiC. If the user does not follow the instructions given in this manual, LiCONiC does not take any responsibility for injuries or damages caused by the LiCONiC product.

Contact Address

LiCONiC AG
Industriestrasse 8
FL - 9493 Mauren
Principality of Liechtenstein

Telephone: +423 373 63 39
Telex: +423 373 53 59
E-mail: info@liconic.com
Internet: www.liconic.com

Before operating the instrument, the user must read and understand this manual.

Installation and Servicing

Installation, servicing and reinstallation of the instrument shall only be performed by System Integrators and / or service personnel authorized by LiCONiC AG.

LiCONiC regularly offers Operator Training Courses. We highly recommend the attendance of such a course prior to working with a LiCONiC Instrument.

Table of Contents

Introduction	6
1. About the Product and this Manual	6
1.1 Intended Use	6
1.2 Unintended Use	6
1.3 Product Identification	6
1.4 Scope of Delivery	6
1.5 General	7
1.6 Definitions	7
1.7 Target User Group	7
1.8 Importance of the Safety Instructions	7
1.9 Labels	8
1.10 Safety - Basics	8
1.10.1 General Operating Hazards	8
1.10.2 Mechanical Hazards	8
1.10.3 Electrical Hazards	8
1.10.4 Chemical, Biological and Radioactive Hazards	8
1.10.5 Extreme Temperature Hazards	9
1.10.6 Suffocation Hazard	9
1.11 General Safety Regulations	10
1.11.1 Legal Requirements	10
1.11.2 General Inspection and Maintenance Duties	10
1.11.3 Spare Parts to be used	10
1.11.4 Modifications	10
General	11
2. The Kiwi Store SAB Series	11
2.1 Kiwi Store SAB	11
2.2 Kiwi Store SAB Features	11
2.3 Kiwi Store Configuration and Capacity Overview	12
Options	14
3. Kiwi Store Configurations	14
3.1 Kiwi Store SAB ULT	14
4. Climate of LiCONiC Kiwi Stores SAB	15
4.1 Overview	15
4.2 Cooling	15
4.3 Temperature	15
4.4 Humidity	16
5. Backup solutions for Kiwi Stores SAB	16
5.1 Overview	16
5.2 Auxiliary Refrigeration DF	17
5.2.1 Auxiliary Refrigeration Kiwi Store SAB DF	17
5.3 Auxiliary Refrigeration ULT	17
5.4 CO2 Backup cooling	17
5.5 LN2 Backup cooling	18
Identification	19
5.6 Handheld 1D Barcode Scanner	19
5.6.1 Supported Barcode Types	19
5.6.2 Barcode Scanner Specifications	20
5.7 2D Code rack scanner	20
5.7.1 Supported 2D code Types	20
5.7.2 2D code scanner / reader Specifications	20
6. Kiwi Store SAB Cassettes	22
System Installation	23
7. KiWi Store SAB installation	23
7.1 Customer installation guide	23

7.2	3D-View	23
7.3	Top view.....	24
7.4	Panel Locations.....	25
7.5	General Requirements.....	26
7.6	Clearance Requirements	26
8.	Refrigeration	26
8.1	Refrigeration Elements Overview.....	26
8.2	Electrical Refrigeration Principles.....	27
8.3	Cold Water Cooler.....	27
8.4	Connections Cooler to Cold Store.....	28
8.5	Typical Water Cooler Integration.....	29
8.6	Cooling Water Connection.....	30
8.7	Requirements Cooling Water.....	31
8.8	LN2 Backup Connections	32
8.9	LN2 Requirements.....	32
9.	Electrics.....	33
9.1	Overview.....	33
9.2	Electrical Connections Store.....	33
9.3	Electrical Connections Cooling units	34
9.4	Electrical Connections Interface.....	35
9.5	Requirements.....	35
9.6	Gassing Installation	36
9.6.1	Kiwi Store Gassing and Backup Options	36
9.6.2	Safety Information	36
9.6.3	Installation Safety Recommendations	38
9.6.4	Gassing System Installation.....	41
9.6.5	Specific Advice for CO2 Carbon Dioxide.....	42
9.6.6	Specific Advice for N2 Nitrogen	44
9.6.7	Principles of Operation of Gassing Options	45
9.6.8	Integrated Gassing Safety Features.....	48
9.6.9	Backup Refrigeration installation	50
9.6.10	Specific Advice for LN2 Liquid Nitrogen.....	51
9.6.11	Refill LN2 Liquid Nitrogen cylinder	52
9.6.12	Refill LCO2 Liquid CO2.....	53
Manual Operation		54
10.	Alert System	54
10.1	SAB Alerts.....	54
11.	Doors.....	54
11.1	User door	54
12.	Cassettes.....	55
13.	Barcode Reader.....	58
13.1	Handheld 1D Scanner for plates and Cryo Boxes	58
13.2	2D Scanner / Reader for tubes	58
14.	Power-On SAB	59
15.	Climate Settings.....	60
15.1	Temperature Settings	60
15.2	Humidity Settings	60
16.	Cooling unit operation.....	60
16.1	Switch on cooling SAB DF	60
16.2	Switch on cooling SAB ULT	61
16.3	Recovery after Backup activation.....	63
16.3.1	Procedure.....	63
16.4	Service operation of backup cooling	64
16.4.1	Procedure.....	64
17.	Routine Safety Checks	65
Software.....		66
18.	Sample Management Software.....	66
18.1	Order File.....	66
18.1.1	Plate retrieval.....	66

18.1.2	Sample retrieval	67
18.2	PlateExplorer.....	68
18.2.1	Plate content import	68
18.2.2	Import.....	69
18.2.3	Export.....	73
18.2.4	Manual Operations	78
18.2.5	Layout of the PlateExplorer.....	79
Safety Sheets.....		81

Introduction

1. About the Product and this Manual

1.1 Intended Use

The LiCONiC Kiwi Store is intended for storage, identification and transfer of Microplates and Tubes. It is to be applied exclusively in the research field. The LiCONiC Kiwi Store is intended to work as a stand alone unit or an element in an automated system.

1.2 Unintended Use

Due to its open architecture, the LiCONiC Kiwi Store is NOT intended for regulated clinical and diagnostic applications (IvD Directive).

Read the safety instructions in this Manual carefully.

1.3 Product Identification

The Type Plate is located at the rear of the LiCONiC SAB

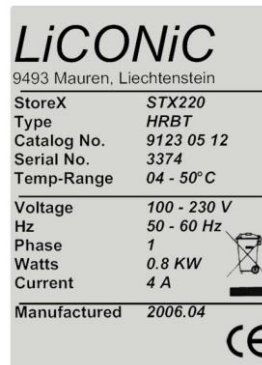

LiCONiC	
9493 Mauren, Liechtenstein	
StoreX	STX220
Type	HRBT
Catalog No.	9123 05 12
Serial No.	3374
Temp-Range	04 - 50° C
<hr/>	
Voltage	100 - 230 V
Hz	50 - 60 Hz
Phase	1
Watts	0.8 KW
Current	4 A
<hr/>	
Manufactured	2006.04
	

For future reference, please read the instrument Serial No. on the rear of your instrument and write it in the provided space.

1.4 Scope of Delivery

- Basic Unit, consisting of a Cassette Lift, an antechamber and the storage chamber
- Cooling unit for storage chamber
- Cooling unit for antechamber
- Product Documents
- Cables
- User Software and Drivers
- Cassettes (as specified)
- Redundant Cooling (only if ordered)
- LN2 Backup (only if ordered, does not include DEWAR)

Exact delivery scope may differ according to project scope

1.5 General

The LiCONiC Kiwi Store is a complete product for end users. Setup of equipment is conducted by LiCONiC Engineers or by LiCONiC trained and certified personnel.

1.6 Definitions

Operator:	Any person who uses the equipment for its intended purpose.
Authorized Engineer	Authorized person responsible for installation, initial start up. Person who carries out service and maintenance tasks and is therefore contacted in the case of any problems with the system.
Plate	Any SBS-Format sample plate or tube rack.
Cryo Box	Storage card board box for cryo tubes
Samples	Any individual container containing sample material, tubes, vials and so on.

1.7 Target User Group

The Kiwi Store has been conceived for applications in the research field.

Instrument operation requires a trained user.

1.8 Importance of the Safety Instructions

This chapter contains general information assuring safe operation of the instrument. More specific instructions in regard to safety are given throughout this manual, at the respective points where observation is most important.

Make sure that all Safety Instructions in this publication are strictly followed.

1.9 Labels

Throughout this publication, Warning Notices are to be interpreted as follows:



WARNING !

Indicates the possibility of severe personal injury, loss of life or equipment damage if instructions are not followed.



CAUTION !

Indicates the possibility of severe equipment damage if instructions are not followed.



NOTE !

Gives helpful information about the equipment.



DANGER !

May be harmful to your eyes.

1.10 Safety - Basics

1.10.1 General Operating Hazards

Carefully observe the following precautions:

1.10.2 Mechanical Hazards

Keep the housing and safety panels closed and never reach into the instrument workspace when the unit is in operating mode. Ensure safety of user prior to any tasks sent to the equipment.

1.10.3 Electrical Hazards

Keep the housing and safety panels closed. Before opening any of the panels disconnect the power supply to avoid electrical shock.

1.10.4 Chemical, Biological and Radioactive Hazards

All samples and test-kit components must be considered as potentially hazardous agents. Therefore, a potential risk may arise from the liquids being handled, such as infectious biological samples, toxic or corrosive chemicals, or radioactive substances. Strictly apply appropriate safety precautions according to local, state and federal regulations.

Prior to any first time application, test runs should be made with a neutral liquid to allow optimization of all liquid handling parameters.

Handling and disposing of waste has to be in accordance with all local, state and federal environmental, health and safety laws and regulations.

Prior to executing any maintenance task on the instrument or sending it, or parts of it for repair, the instrument or the parts have to be thoroughly decontaminated.

1.10.5 Extreme Temperature Hazards

All surfaces inside the storage chambers, ante chamber and some parts of the refrigeration may be considered as potentially dangerous if touched without sufficient protective clothing. All components externally to the chamber are protected and are not able to be touched. Only if protective covers are removed components with extreme cold or heat may be touchable.

Inside the chamber temperatures below zero degree Celsius are present. Contact to any surfaces with bear skin should be avoided. Protective clothing has to be worn when manual operations are performed inside the chamber.

1.10.6 Suffocation Hazard

When entering the ante chamber and service area of the Storage chamber a potential risk of suffocation is present. A maximum of 15 minutes is given to stay in them without a respirator. When entering a O2 monitor has to be worn under any circumstances. The monitor has to provide at least an adjustable O2 low limit and an acoustic alert when O2 level is too low.



WARNING !	
➤	Inert gases are asphyxiating and will displace oxygen to produce localized oxygen deficient atmospheres
➤	Inert gases are odorless, colorless and tasteless
➤	Inert gases give no warning and may cause death in few seconds
➤	The Exhaust of the CO2 or LN2 backup cooling option needs to be led out of the building otherwise danger of suffocation is immanent
➤	In their liquid state inert gases are extremely cold fluids which can cause serious burns when in contact with the skin
➤	A cryogenic spill often gives a low-lying cloud of vapor that creeps along the ground
➤	Due to very specific local rules and regulations in different countries it is the customers / owner's responsibility to install suitable oxygen (O2) and carbon dioxide (CO2) monitor systems which trigger alarms to protect operators in and around the SAB store.
➤	Dry ice (solid CO2) has never to be stored in the Ante Chamber or Service Area due to concentration increase in CO2. CO2/O2 monitoring is mandatory when dry ice is used for sample transport.

It is not allowed to work inside the system alone. A second person has to be outside surveying the work inside and to be in permanent contact with a radio with the person inside.

1.11 General Safety Regulations

1.11.1 Legal Requirements

Please consult the Manufacturer's Declaration, delivered with each unit by LiCONiC AG, listing all applied directives and standards.

In Europe, the System Integrator must provide a Conformity Declaration upon final installation of the entire system.

1.11.2 General Inspection and Maintenance Duties

Only an authorized Engineer shall carry out inspection, maintenance and repair tasks.

1.11.3 Spare Parts to be used

Only original LiCONiC Spare Parts may be used. If other parts are used during the normal warranty period, the manufacturer's guarantee may be invalidated.

1.11.4 Modifications

Modifications shall only be carried out by an authorized Engineer. LiCONiC AG will not accept responsibility for any claim resulting from unauthorized modification or alteration.

General

2. The Kiwi Store SAB Series

2.1 Kiwi Store SAB

The Kiwi Store SAB is the most compact storage with integrated cassette handling that covers semi-automated plate and Cryo Box storage needs at -20°C and -80°C . The Kiwi Store SAB Series offers dry climate storage.

The modular mechanical design in combination with extremely simple commands eases the use of a Kiwi Store SAB in any environment. A growing number of accessories are available for the Kiwi Store SAB Series.

2.2 Kiwi Store SAB Features

All Kiwi Store SAB units have compact dimensions. The Kiwi Store SAB has a user front door, which allows comfortable and easy access to the ante chamber. The antechamber is the operation space for the manual transfer of racks and plates from any additional equipment or transport box into the actual storage area. Exchangeable cassettes make the use of the Kiwi Store SAB extremely flexible. Cassettes are available for all common plate types and Cryo Boxes.

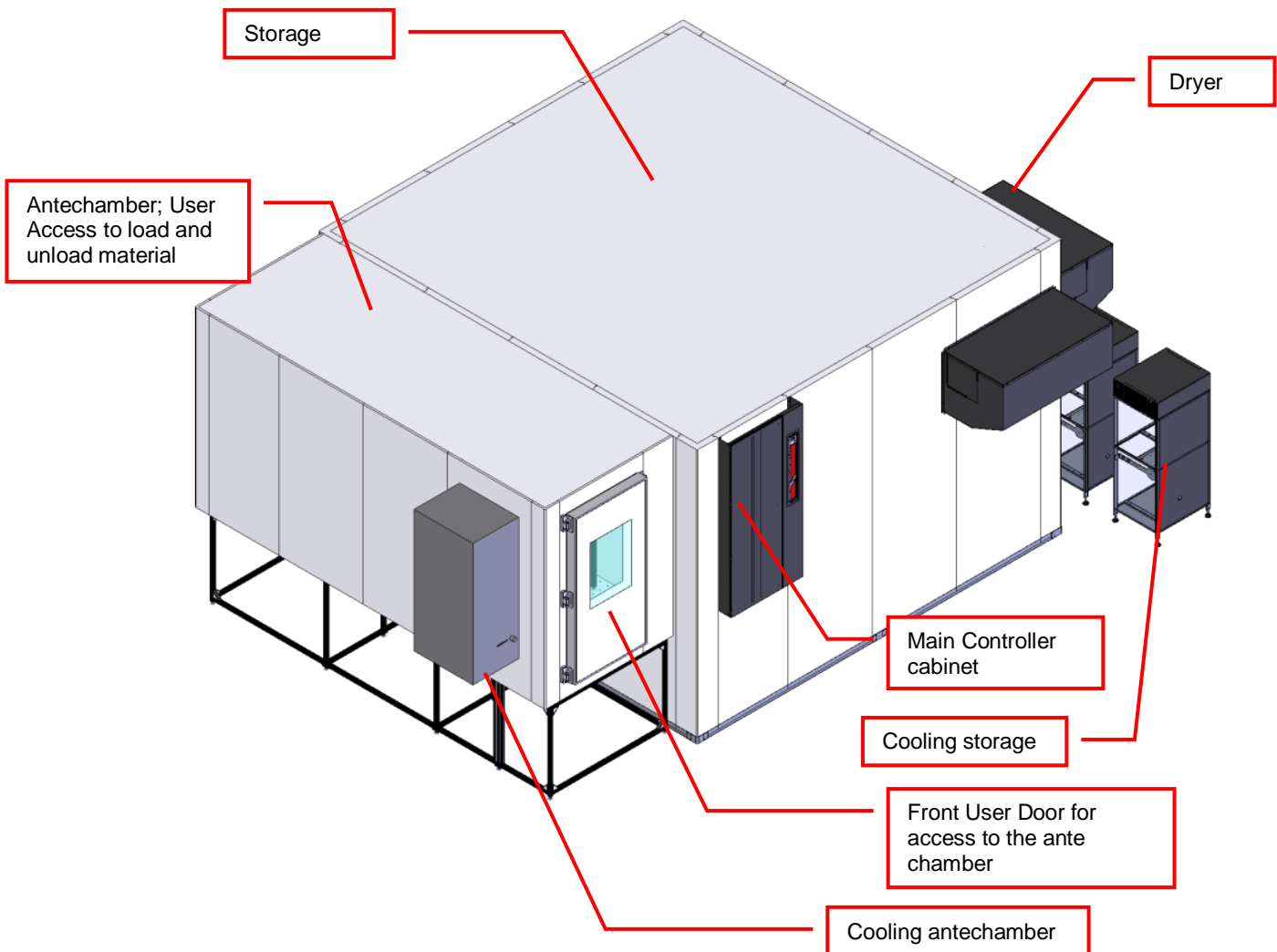

Dimensions for 864/1260 Configuration :

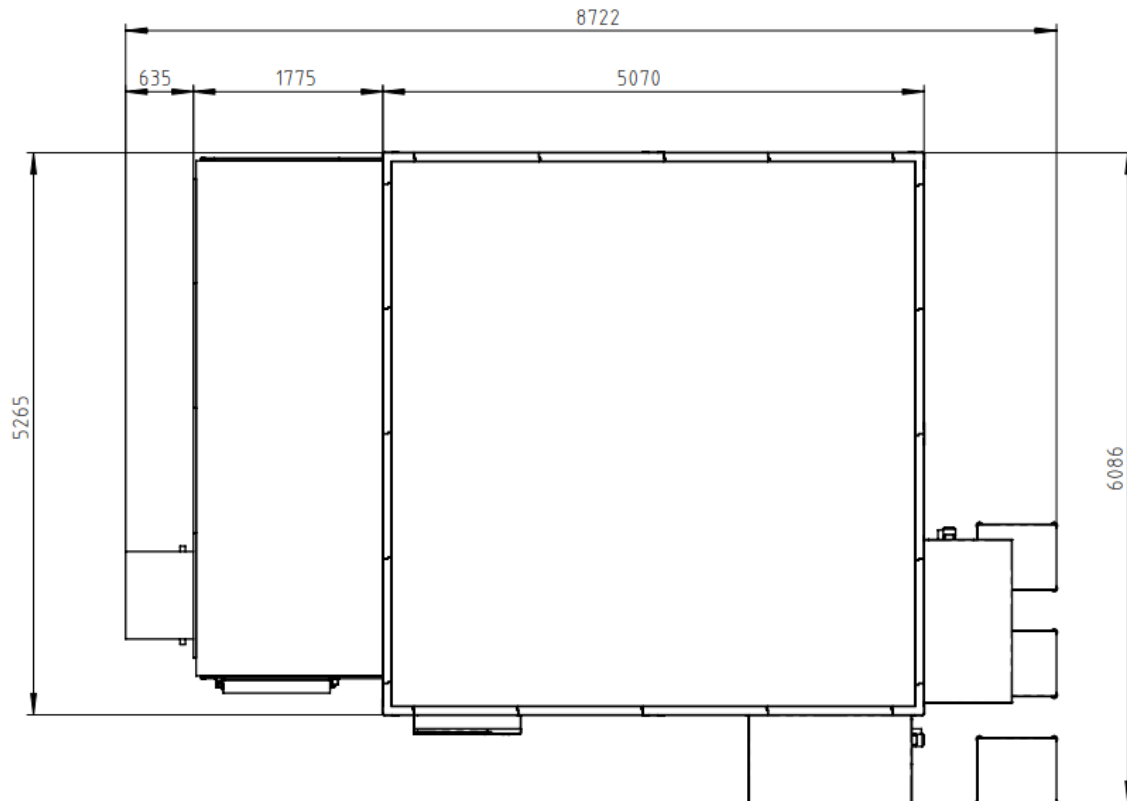
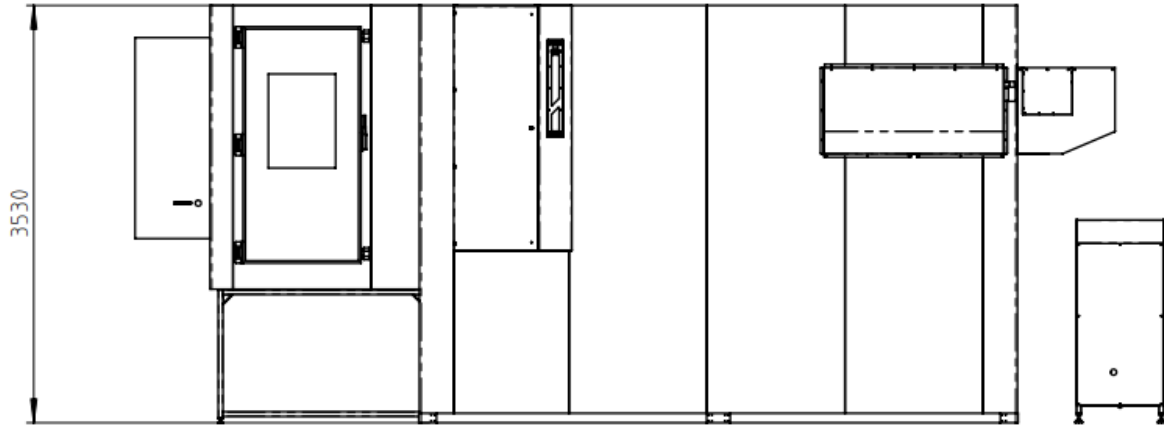

2.3 Kiwi Store Configuration and Capacity Overview

The Family of Kiwi Store SAB is structured by their capacity for storage cassettes and their climate.

The Kiwi Stores SAB are Stand Alone for manual semi-automated operation.

Capacity, given in Cassettes

Kiwi Store SAB	No. of SBS Cassettes	Height of Cassettes
864 / 1260	864	1260 mm
864 / 1775	864	1775 mm
864 / 1960	864	1960 mm
1152 / 1260	1152	1260 mm
1152 / 1775	1152	1775 mm
1152 / 1960	1152	1960 mm

These capacities are an excerpt of the most commonly requested sizes. Further Storage sizes are available on request. All Kiwi Stores can handle and store a wide range of types of plates and racks with SBS standard format. The corresponding capacity is only depending of the height of the racks and if the racks / plates are stored in separate levels or stacked on each other. Special formats such as cryo boxes and larger sizes are available upon request.

For further systems dimensions please contact LiCONiC AG. These Dimensions are examples and are not binding.

Options

3. Kiwi Store Configurations

3.1 Kiwi Store SAB ULT

The Kiwi Store SAB is the most compact storage with integrated cassette handling that covers semi-automated plate and Cryo Box storage needs at -20°C and -80°C . The Kiwi Store SAB Series offers dry climate storage.

The modular mechanical design in combination with extremely simple commands eases the use of a Kiwi Store SAB in any environment. A growing number of accessories are available for the Kiwi Store SAB Series.

All Kiwi Store SAB units have compact dimensions. The Kiwi Store SAB has a user front door which allows comfortable and easy access to the ante chamber. The ante chamber is the operation space for the manual transfer of racks and plates from any additional equipment or transport box into the actual storage area. Exchangeable cassettes make the use of the Kiwi Store SAB extremely flexible. Cassettes are available for all common plate types and Cryo Boxes.

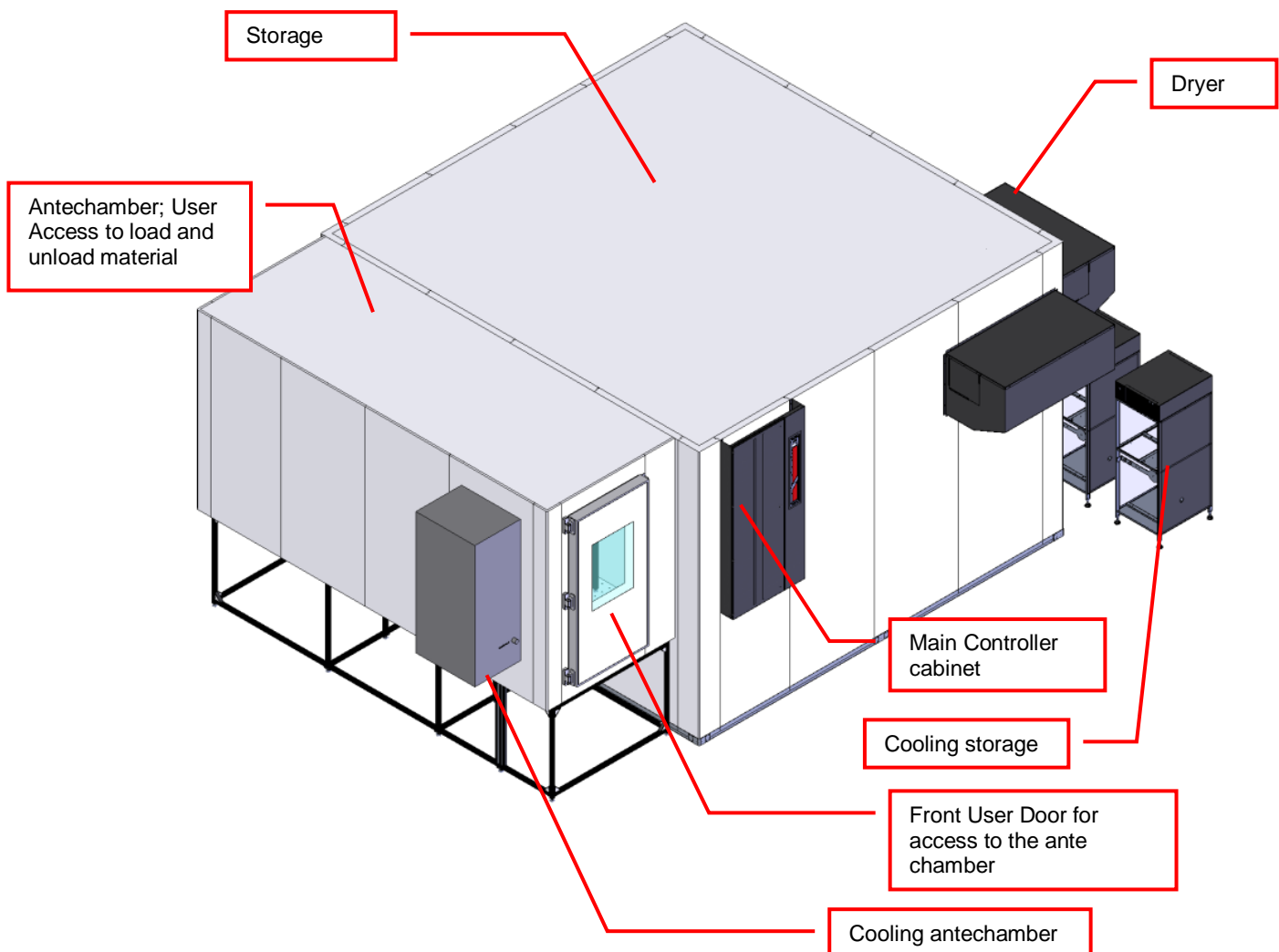

4. Climate of LiCONiC Kiwi Stores SAB

4.1 Overview

Name	Temperature	Humidity
DF Deep Freezer	-20..00°C	02..45%RH
ULT Ultra low temperature	-80°C	n.a.

The KiWi SAB DF Stores are designated for the use as compound storage, whereas the ULT version is mainly for Biobanking use.

4.2 Cooling

Within all units the air in the DF (-20°C) part, is actively dried by forcing the air through an evaporator. This allows cooling and actively drying the air. Since the evaporator gets covered with ice after a certain time these units have an automatic defrost function. The collected water will be exhausted through a drain.

For DF Storage units this does apply for the complete storage area. In case of the ULT systems the active drying is done in the user access chamber, the ante chamber and the service area.

4.3 Temperature

All units are equipped with a Temperature-Sensor. This allows displaying the temperature inside the storage chamber. A very high quality sensor is used for this purpose. Quality and accuracy of the sensor is maintained by the Swiss Federal Office of Metrology and the Swiss Accreditation Service (see specifications in next chapter).

Due to the limited temperature range this sensor is used in the ULT storage systems to monitor and control the climate in the service area and the ante chamber. To monitor all other temperature, such as parameters of cooling and storage chamber temperature, thermocouples are used.

4.4 Humidity

All units are equipped with an rH-Sensor. This allows displaying the humidity inside the storage chamber. A very high quality sensor is used for this purpose. Quality and accuracy of the sensor is maintained by the Swiss Federal Office of Metrology and the Swiss Accreditation Service.

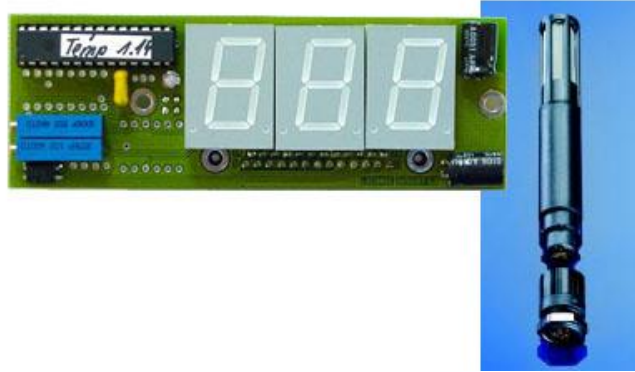

The Humidity sensors used in the Kiwi Store series are suitable for extremely high humidity as well as for extreme dryness. They incorporate a humidity and a temperature sensor allowing a relative humidity (rH) readout.

Specifications

Measuring Range	0..100	% RH
Accuracy @23°C	±1.5 ±1.3	% RH °K Temp.
Resolution	12 12	Bit / 0.02% Bit / 0.1°C
Sensor	PT100 C94	Temperature Humidity
Adjustment	-	E2-PROM

5. Backup solutions for Kiwi Stores SAB

5.1 Overview

Name	Temperature	Principle
Auxiliary Refrigeration DF	-20..00°C	2 nd Refrigeration unit
Auxiliary Refrigeration ULT	-80°C	2 nd Refrigeration unit
CO2 Backup	-20°C	Evaporator for CO2
LN2 Backup	-80°C	Evaporator for LN2

The Kiwi Store auxiliary refrigeration units mainly cover the case of a failure of the main cooling unit whereas the gas backup solutions are made to cover power outages.

5.2 Auxiliary Refrigeration DF

All Kiwi Store SAB units can be equipped with an auxiliary refrigeration.

5.2.1 Auxiliary Refrigeration Kiwi Store SAB DF

The Kiwi Store SAB have a refrigeration unit placed at the side of the system. Therefore easily an additional refrigeration unit can be placed next to the main refrigeration.

To provide the complete redundancy a second evaporator is installed inside of the storage chamber. The auxiliary refrigeration is equal to the main refrigeration and therefore can provide the same cooling performance as the main unit.

5.3 Auxiliary Refrigeration ULT

As for the DF units the ULT auxiliary refrigeration solution is realized with a second refrigeration unit. The main unit is running all the time to maintain the temperature. The auxiliary refrigeration takes over during failure of the main cooling unit or to assist the main unit during cool down. The auxiliary cooling unit is equipped with its own control an monitoring PLC and is therefore completely independent of the main control.

5.4 CO2 Backup cooling

The CO2 Backup solution is mainly for the use in DF systems to maintain the temperature during power failure. Furthermore the CO2 option could also be used for backup on ULT units. The CO2 bottle is connected to a controlled inlet to the chamber injecting CO2 to maintain cold.

This option includes the tubing and the control. This backup solution is fully monitored to ensure the temperature to stay at -20°C . Also an exhaust is part of this option. For ULT unit an adapted regulation is in use to ensure to stay below -70°C .

If the CO2 backup cooling is coming into action large amounts of CO2 are released through the options exhaust. Therefore the exhaust needs to be lead out of the building to not endanger personnel working in the area of the system.



WARNING !	
➤	Inert gases are asphyxiates and will displace oxygen to produce localized oxygen deficient atmospheres
➤	Inert gases are odorless, colorless and tasteless
➤	Inert gases give no warning and may cause death in few seconds
➤	The Exhaust of the CO2 backup cooling option needs to be lead out of the building otherwise danger of suffocation is immanent
➤	In their liquid state inert gases are extremely cold fluids which can cause serious burns when in contact with the skin
➤	A cryogenic spill often gives a low lying cloud of vapor that creeps along the ground
➤	Due to very specific local rules and regulations in different countries it is the customers / owners responsibility to install suitable oxygen (O2) and carbon dioxide (CO2) monitor systems which trigger alarms to protect operators in and around the SAB store.

5.5 LN2 Backup cooling

The LN2 Backup solution is intended for the use in ULT systems to maintain the temperature during power failure. A LN2 Dewar, or alternatively a direct connection to a large storage tank, is connected to an additional evaporator specially designed for cooling use with LN2.

This option includes the evaporator, the tubing and the control, the Dewar or the connection to a storage tank is not included. The size of the Dewar is defined by the desired backup time and the desired refill interval. This backup solution is fully monitored to ensure the temperature is maintained. Also an exhaust is part of this option.

If the LN2 backup cooling is coming into action large amounts of N2-Gas are released through the options exhaust. Therefore the exhaust needs to be lead out of the building to not endanger personnel working in the area of the system.



WARNING !	
➤	Inert gases are asphyxiates and will displace oxygen to produce localized oxygen deficient atmospheres
	Inert gases are odorless, colorless and tasteless
	Inert gases give no warning and may cause death in few seconds
	The Exhaust of the LN2 backup cooling option needs to be lead out of the building otherwise danger of suffocation is immanent
	In their liquid state inert gases are extremely cold fluids which can cause serious burns when in contact with the skin
	A cryogenic spill often gives a low lying cloud of vapor that creeps along the ground
	Due to very specific local rules and regulations in different countries it is the customers / owners responsibility to install suitable oxygen (O2) and carbon dioxide (CO2) monitor systems which trigger alarms to protect operators in and around the SAB store.

- | | |
|---|---|
| ➤ | Inert gases are asphyxiates and will displace oxygen to produce localized oxygen deficient atmospheres |
| | Inert gases are odorless, colorless and tasteless |
| | Inert gases give no warning and may cause death in few seconds |
| | The Exhaust of the LN2 backup cooling option needs to be lead out of the building otherwise danger of suffocation is immanent |
| | In their liquid state inert gases are extremely cold fluids which can cause serious burns when in contact with the skin |
| | A cryogenic spill often gives a low lying cloud of vapor that creeps along the ground |
| | Due to very specific local rules and regulations in different countries it is the customers / owners responsibility to install suitable oxygen (O2) and carbon dioxide (CO2) monitor systems which trigger alarms to protect operators in and around the SAB store. |

Identification

5.6 Handheld 1D Barcode Scanner

For Identification during import and export a wireless 1D barcode hand scanner is used. The reader is connected directly to the controlling software and could be used throughout the storing and retrieving process for rack/plate identification. The reader does give acoustic feedbacks if the correct/know plate is scanned or a different signal in case the wrong plate or an unknown plate has been scanned.



5.6.1 Supported Barcode Types

The following default barcode types are enabled :

- EAN 8/EAN 13 / UPC A/UPC E without ADD ON
- Interleaved 2/5 4 - 99 characters
- Standard Code 39 1 - 99 characters
- Code 128 1 - 99 characters

The following barcode types are disabled :

EAN 128, ISBT128, Code 93, Codabar, pharmaceutical codes, MSI, Code 11, Code 16K, Code 49 and GS1 DataBar

5.6.2 Barcode Scanner Specifications

- Light Source: VLD
- Wavelength: 630 - 680nm
- Output: 0.9mW
- Class: Class II
EN 60825-1 / CDRH 21 CFR 1040
- Max Resolution: 0.076 mm (3 mils)
- Scan Rate: 35 ± 5 scans / sec

5.7 2D Code rack scanner

A 2D code rack scanner can be integrated into the Liconic software. It allows the reading of 2D Codes of a whole rack at once. To read the 2D code the rack needs to be placed manually onto the reader.

5.7.1 Supported 2D code Types

The optional 2D code reader recognizes the following 2D code types.

- DataMatrix

5.7.2 2D code scanner / reader Specifications

Ziath DataPaq A6 Rack Scanner (suitable outside of climate)

- Scanning Device: Customized flatbed scanner
- Compatible rack vendors
 - Thermo Matrix
 - Thermo Abgene
 - Thermo Nunc
 - Remp
 - Micronic
 - FluidX
 - And all other 2D coded tubes
- Compatible rack sizes: 96, 48, 24
- Export data to Excel, text, XML, rack images
- Database connectivity: SQL Server, Oracle, MySQL, Postgres, HSQL and others [v1.23+]
- Fast Scanning — 5 seconds per rack
- Displays damaged/missing tubes
- One-click scan for any size or brand of tube
- Simple installer — no dongles required
- Multiple scanners/multiple configurations
- 110/220 v automatically selected
- Fully integratable into robotics platforms

Ziath DataPaq Express Rack Reader (suitable for placement in low temperature climate)

- Scanning Device: Customized camera reader
- Compatible rack vendors integrated
 - Thermo Matrix

- Thermo Abgene
- Thermo Nunc
- Remp
- Micronic
- FluidX
- And all other 2D coded tubes
- Compatible rack sizes 96, 48, 24
- Export data to Excel, text, XML, rack images
- Database connectivity: SQL Server, Oracle, MySQL, Postgres, HSQL and others [v1.23+]
- Fast Scanning — 1 second image acquisition
- Displays damaged/missing tubes
- One-click scan for any size or brand of tube
- Simple installer — no dongles required
- Multiple scanners/multiple configurations
- 110/220 v automatically selected
- Fully integratable into robotics platforms



WARNING!

LiCONiC AG is doing there utmost to make sure that real sample location matches the stores database by using barcode readers / scanners and guiding SAB users during store and retrieve process.
But due to the semiautomatic nature of the SAB store the user / customer is finally responsible for sample location by moving them into a particular cassette and associated cassette level manually.

6. Kiwi Store SAB Cassettes

The total cassette capacity depends on the unit size. An example list of the number of cassettes for some predefined units are given in the SAB table below :

Kiwi Store SAB	No. of SBS Cassettes	Height of Cassettes
864 / 1260	864	1260 mm
864 / 1775	864	1775 mm
864 / 1960	864	1960 mm
1152 / 1260	1152	1260 mm
1152 / 1775	1152	1775 mm
1152 / 1960	1152	1960 mm

The SAB cassettes are typically customized to optimize the storage space for the given application. The cassettes are either designed to hold a specific plate / tube rack type, cryo box type or the stacking of plates is applied to further optimize storage capacity.

The Kiwi Store SAB can handle almost every plate in SBS format currently available on the market. Specific formats can be realized upon request. For optimum performance LiCONiC offers a variety of cassettes.

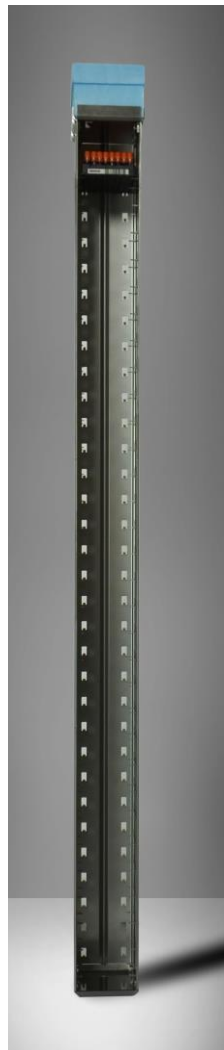

System Installation

7. KiWi Store SAB installation

The installation of the KiWi Store SAB series is only performed by Liconic personnel and in rare cases from thoroughly trained representatives. These systems need major on site installation and adjustments. In this manual only preparations necessary to be done by the customer are described.

7.1 Customer installation guide

7.2 3D-View

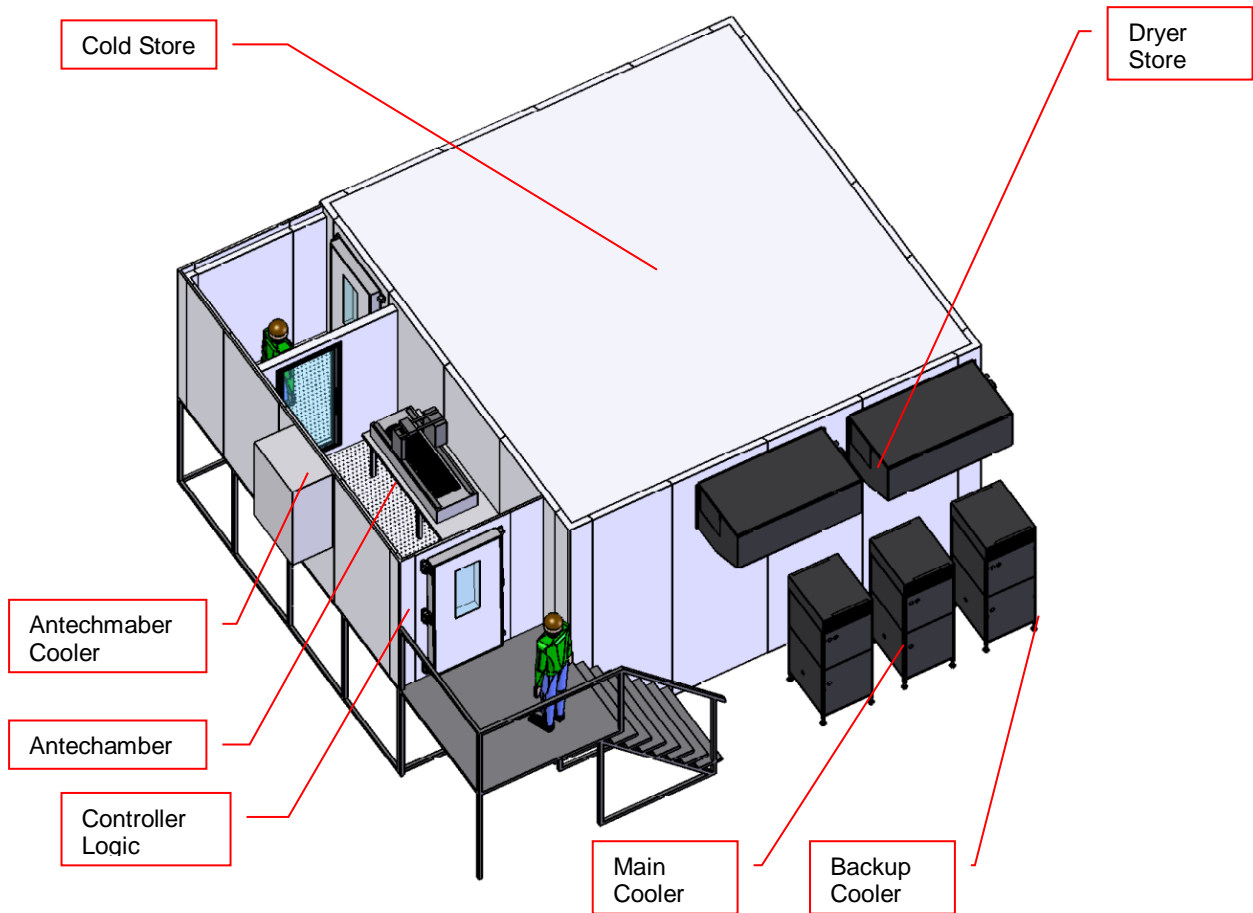

7.3 Top view

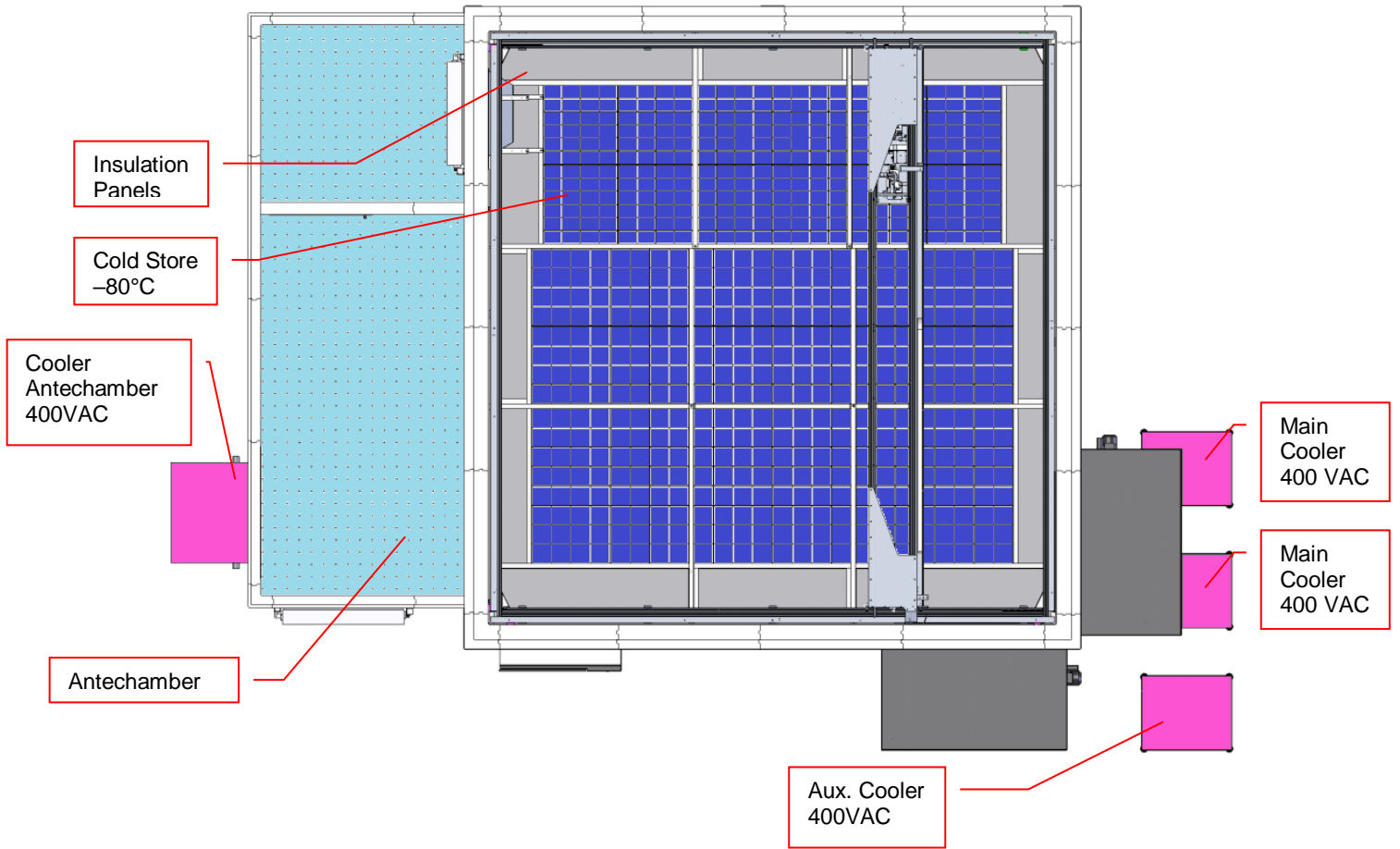

7.4 Panel Locations

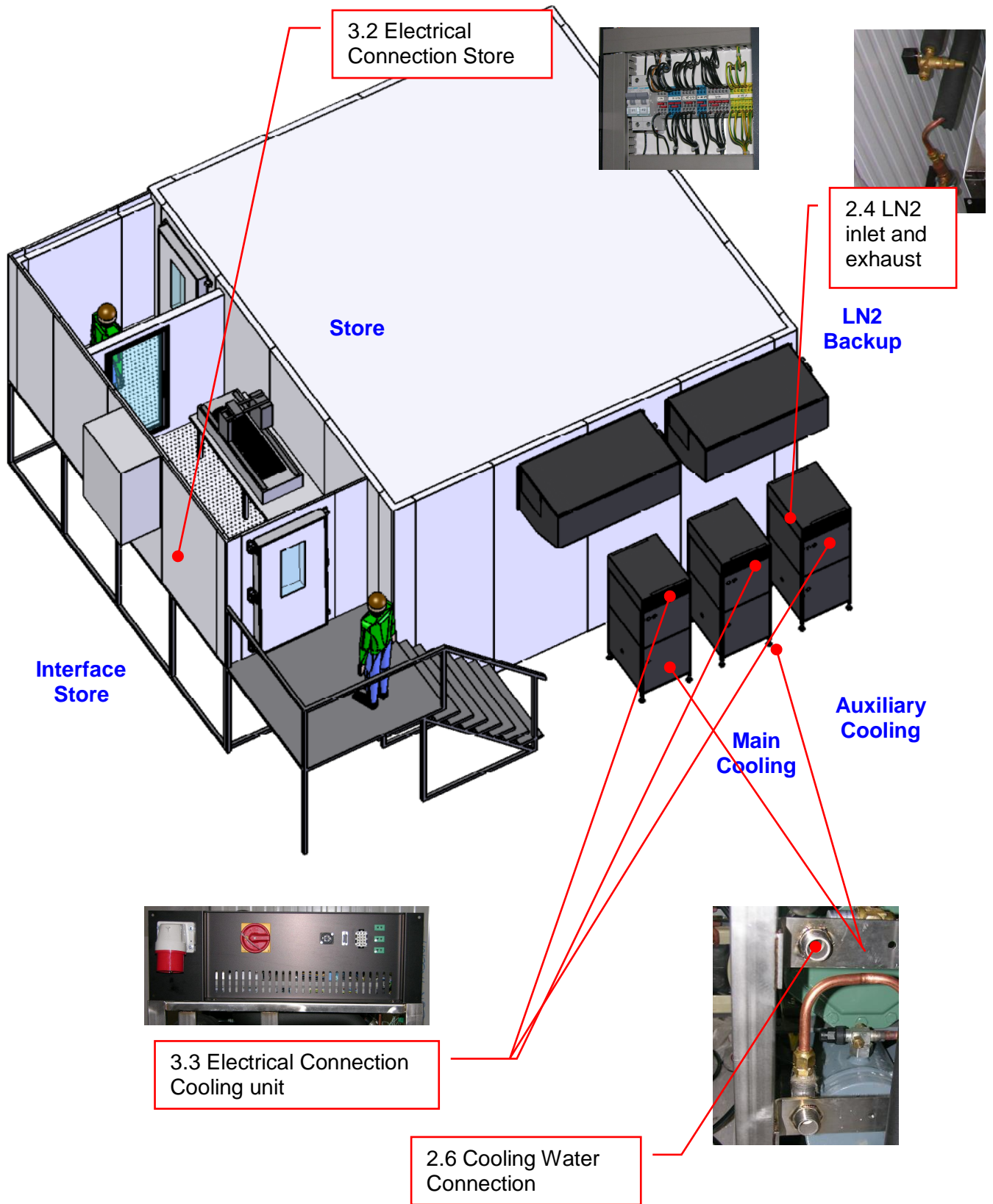

7.5 General Requirements

Requirement	Details
Ambient	Temperature: max. 22 °C Humidity: < 40%
Room height	4 m (If not specified differently)
Ground cooling	10W/m ² (Cooling energy loss passed on to the ground)
Floor load	Recommended 1'000 kg/m ² (for smaller load specifications please consult clearance recommendations with Liconic Applications team, case-by-case approval required)
Point load	250 kg
Heat dissipation	< 2kW
Flatness	+/- 1mm per 1m
Accessibility	Room has to be accessible from 7am - 7pm for installation
Storage	A room has to be supplied to lock in all tools and material
Communication	RJ45 Connector Access to Network

7.6 Clearance Requirements

8. Refrigeration

8.1 Refrigeration Elements Overview

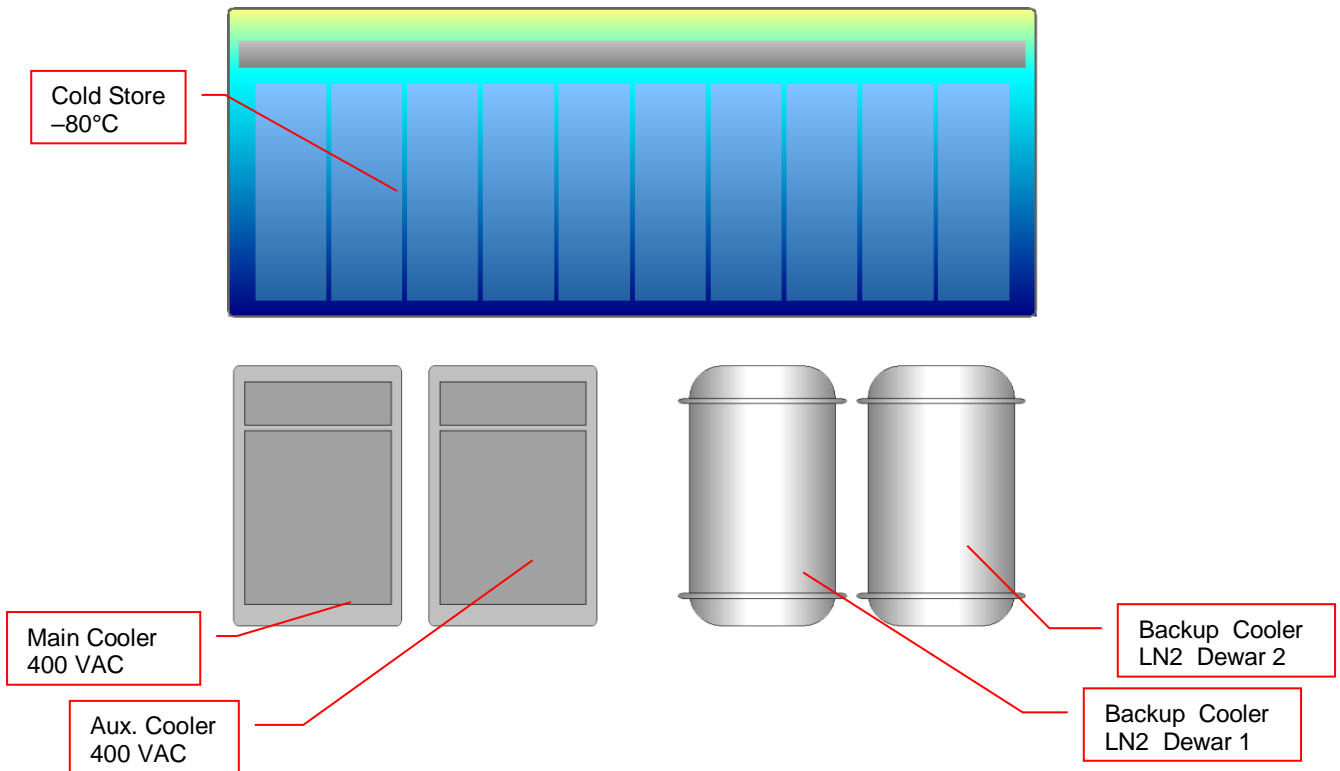

8.2 Electrical Refrigeration Principles

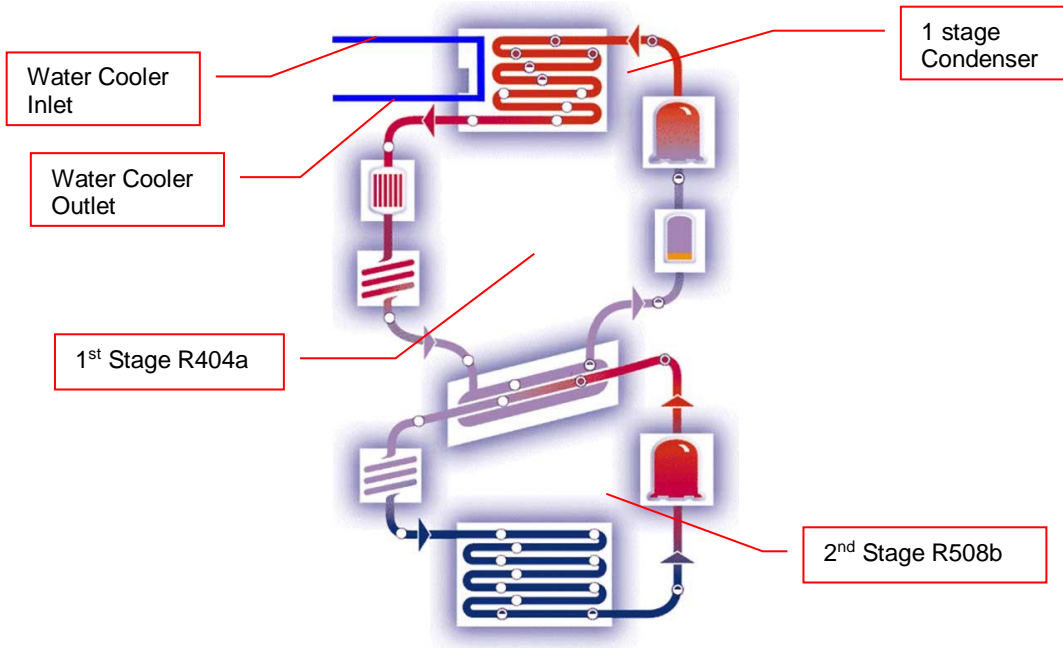

8.3 Cold Water Cooler

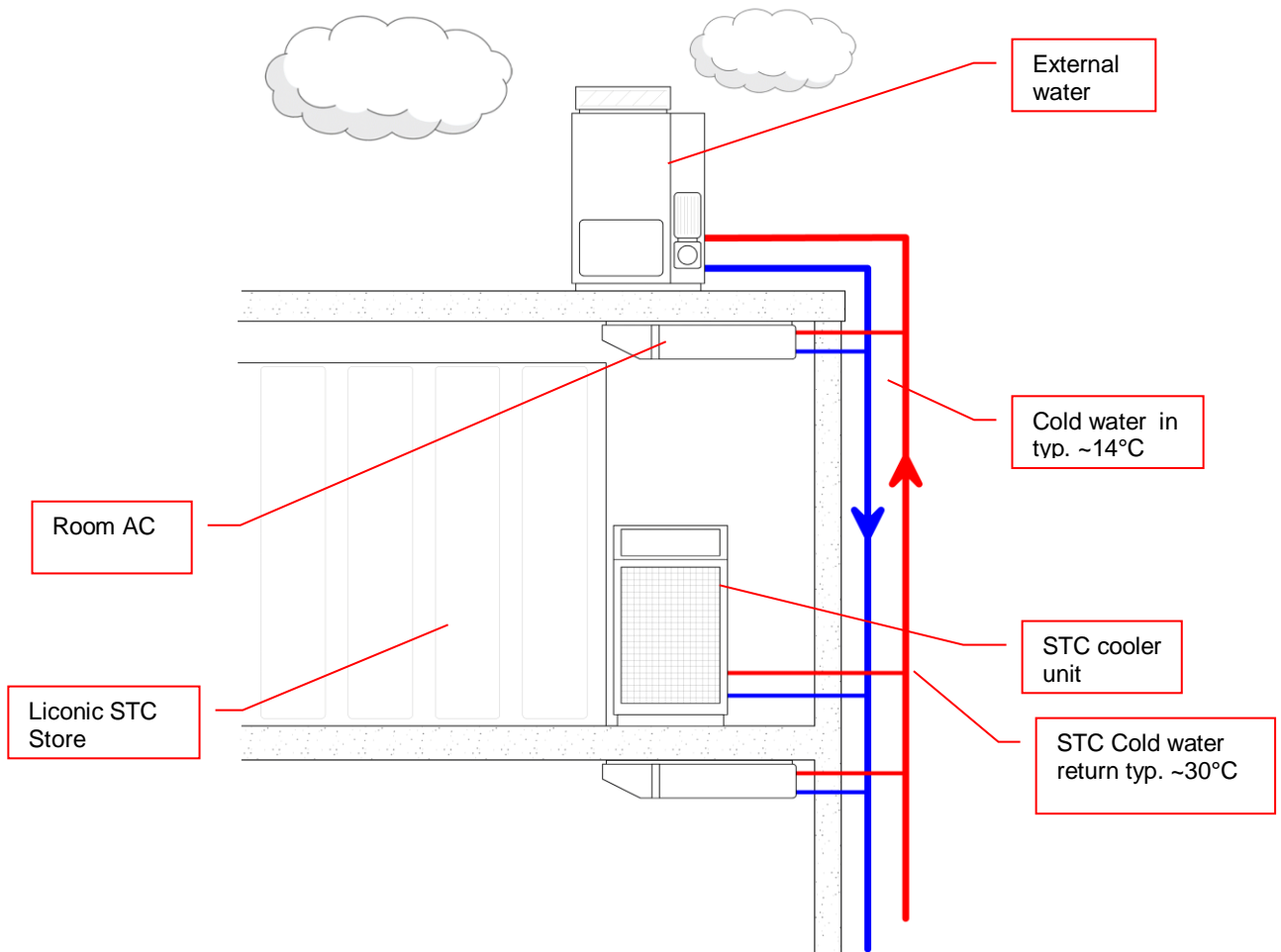

8.4 Connections Cooler to Cold Store

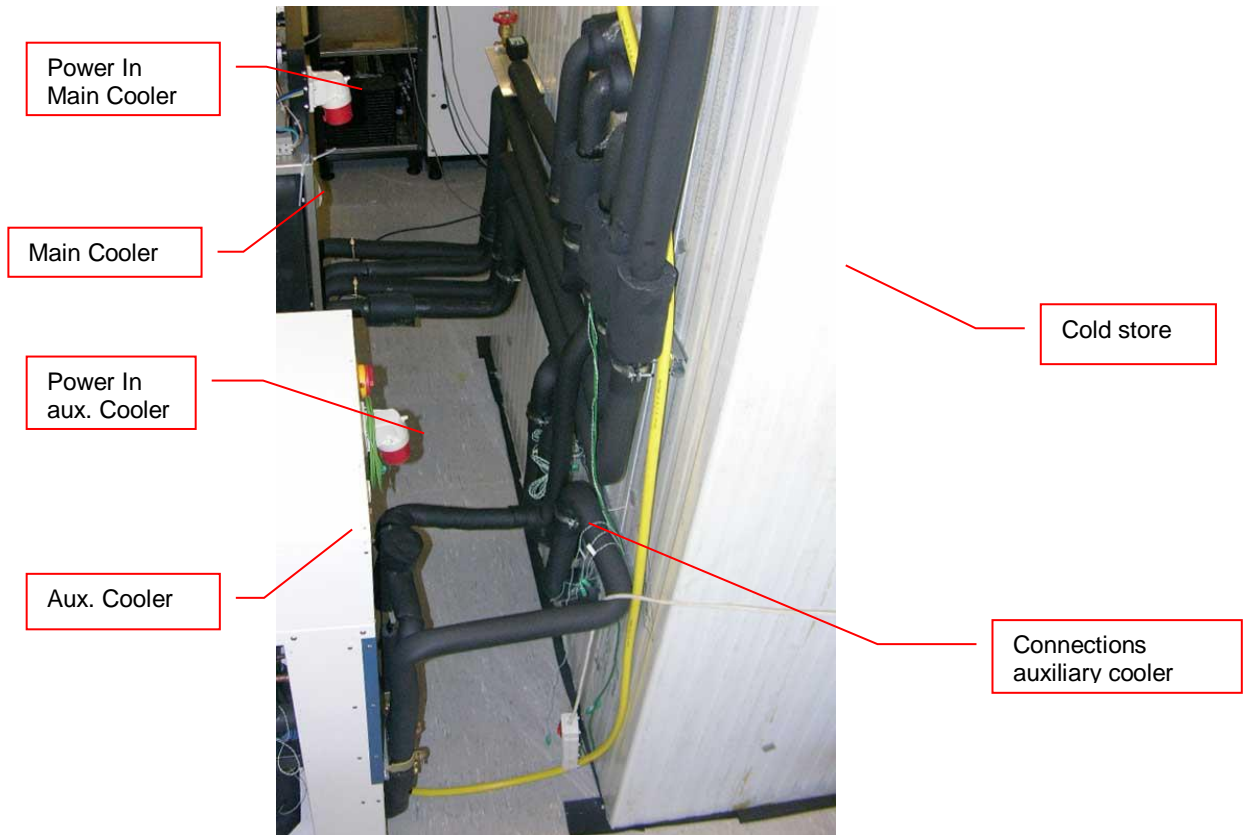
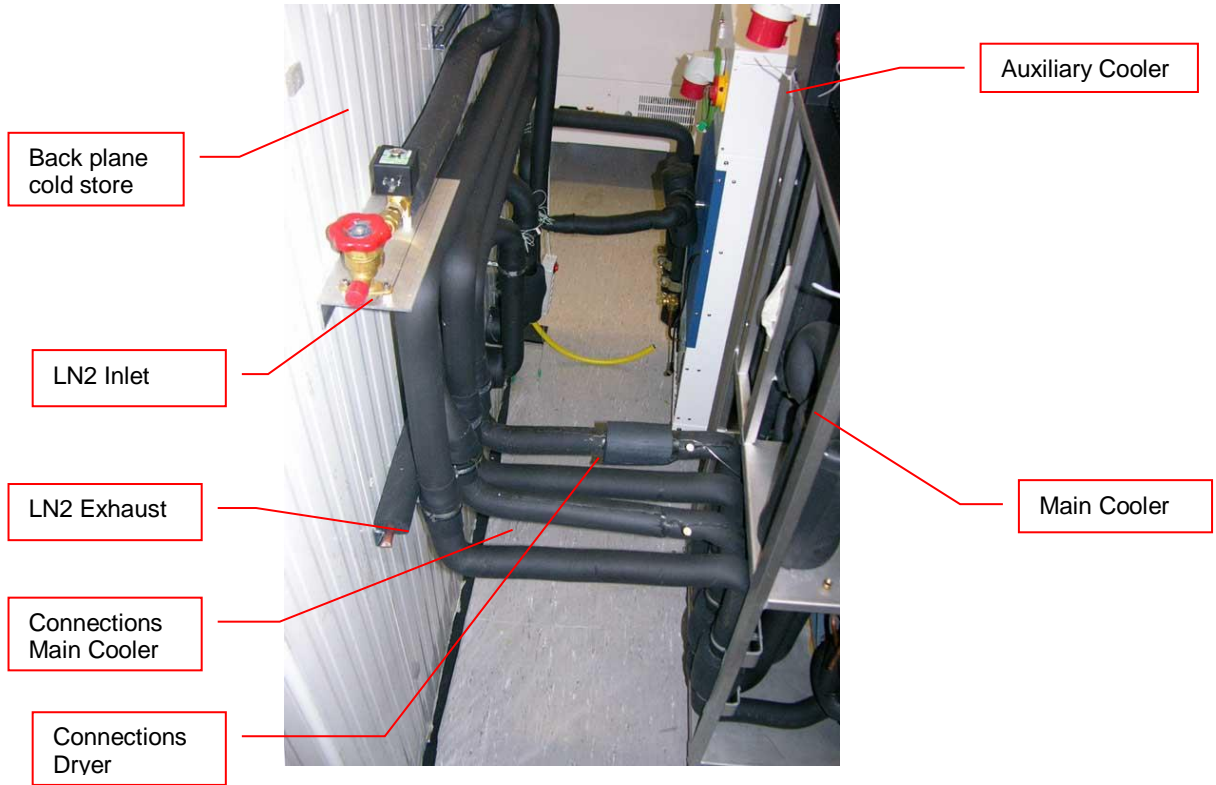

8.5 Typical Water Cooler Integration

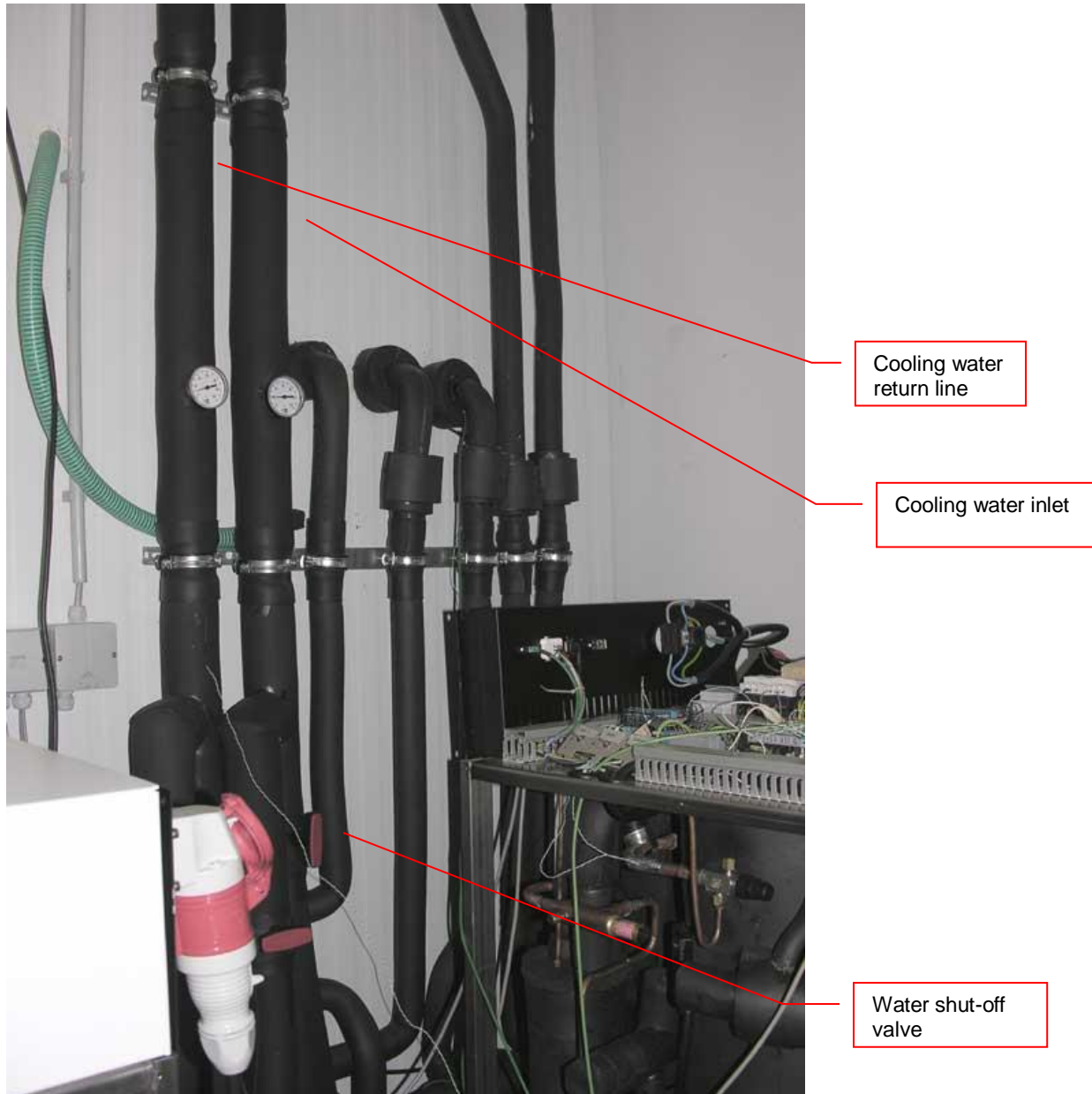

8.6 Cooling Water Connection

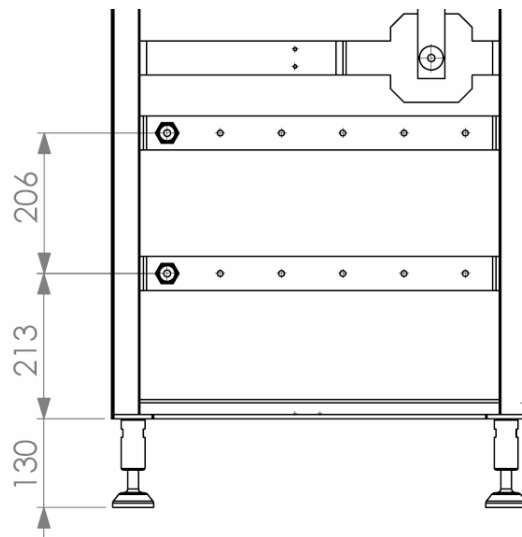

8.7 Requirements Cooling Water

Requirement	Details
Cooling	<p>Media: Water</p> <p>Water quality: Tap water quality, clear</p> <p>Suspended solids: None</p> <p>Conductivity: 50-600 uS/cm</p> <p>Hardness: < 8° dH</p> <p>PH: 7.8</p> <p>CO2 aggressive: None</p> <p>Iron: < 0.3 mg/L</p> <p>Manganese: < 0.05 mg/L</p> <p>Sulfate: < 250 mg/L</p> <p>Chloride: < 250 mg/L</p> <p>COD: < 40 mg/L</p> <p>Bacteria: < 1000 CFU/ml</p> <p>Pressure Difference: 2.5 bar (p.e.: IN 5 bar; OUT 2.5 bar)</p> <p>Max. Inlet Pressure: 10 bar</p> <p>Temperature: IN 5 .. 18 °C</p> <p>Flow: typ. 3-5 l/min @14°C</p> <p>Temperature Return: 35°C</p> <p>Connection fittings: 3/4" male</p> <p>Individual connections for main and redundant cooling</p> <p>Mixture of Water with Glycol are possible.</p>
Typical pump used for cooling loop	
Redundant Cooling	<p>A backup water cooling is highly recommended.</p> <p>Experience showed the vitality of the water cooling. If the water cooling is facing an error both main and redundant cooling units are inhibited to work if connected to the same circuit.</p> <p>Therefore the installation of a redundant or fresh water cooling is recommended.</p>
Water Connections	<p>6x 3/4" male</p> <p>Main: 2x Inlet; 2x Return</p> <p>Auxiliary: 1x Inlet; 1x Drain/Return</p> <p>Interface Compartment: 1x Inlet; 1x Return</p> <p>Auxiliary cooling is highly recommended to be connected to second (redundant) water circuit or fresh water supply.</p>
Drain	<p>Interface Compartment and Storage Dryer may perform regular defrost cycles</p> <p>Interface Compartment and Storage Dryer are equipped with a drain tube leading the gathered water out of them.</p> <p>Solution to remove the water may be foreseen. In the most simple case a evaporation pan could be used. (Water would evaporate into the room over time)</p> <p>More sophisticated solution would be to provide a drain to guide the water out of the room.</p>

8.8 LN2 Backup Connections

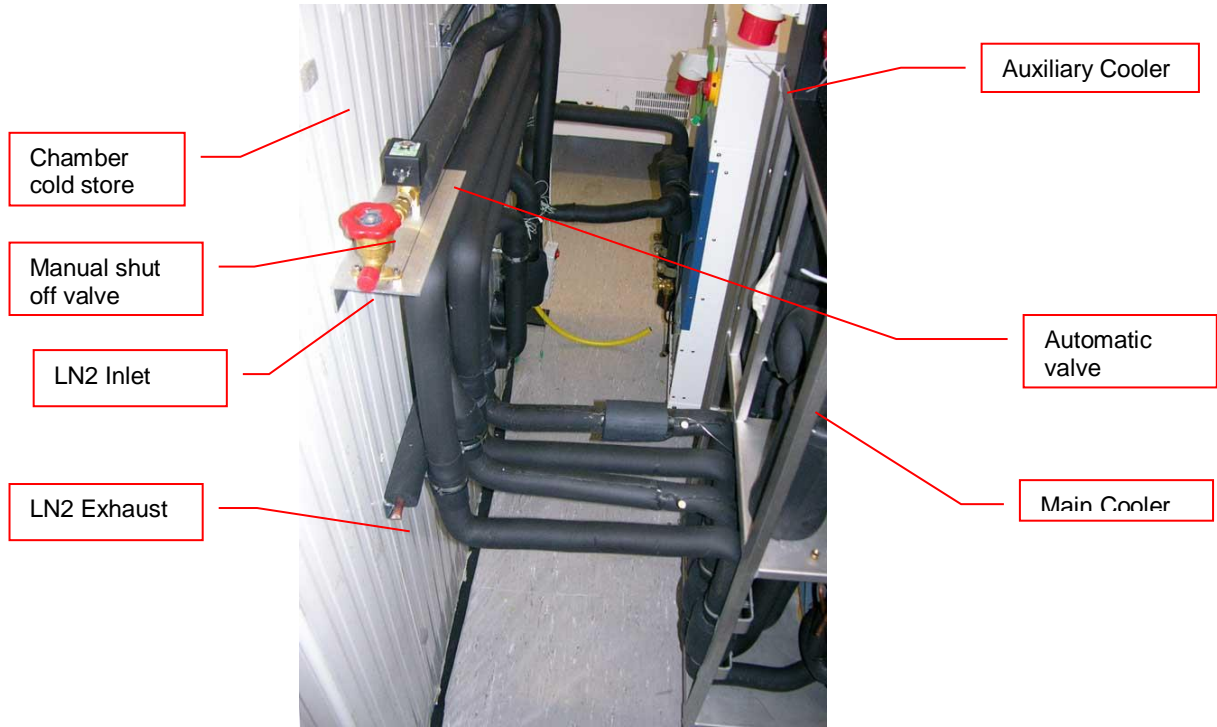

8.9 LN2 Requirements

Requirement	Details
Media	LN2
Refill intervall	Depending on DEWAR-Volume With respect to the Leak rate the DEWAR has to be refilled to maintain the minimum desired backup time. Specifications based on Cryotherm Apollo 350: 24 h Back up = Consumption: 209 - 298 L Refill: about every 28 - 80 days (recommended once a month)
Cooling time	Depending on DEWAR-Volume Specifications based on Cryotherm Apollo 350: 100% filled: typically 28 - 40 h 50% filled: typically 14 - 20 h
LN2 Consumption	7-10 kg/h = 8.7 - 12.4 L/h
Leak rate	Depending on DEWAR Specification based on Cryotherm Apollo 350: 0.5% / Day
Supply Pressure	1.5 bar
Supply Connection	1/2" SAE Male, Manual Shut Off Valve and automatic Valve after connection
N2-Exhauste	Exhaust is necessary. In case of use of backup cooling N2 will be released into the environment The Exhaust has to be guided out of the building.
N2-Exhauste Connection	1/2" Open end copper tubing. A unidirectional valve is installed in the line to prevent any air leaking into the LN2 Backup circuit

9. Electrics

9.1 Overview

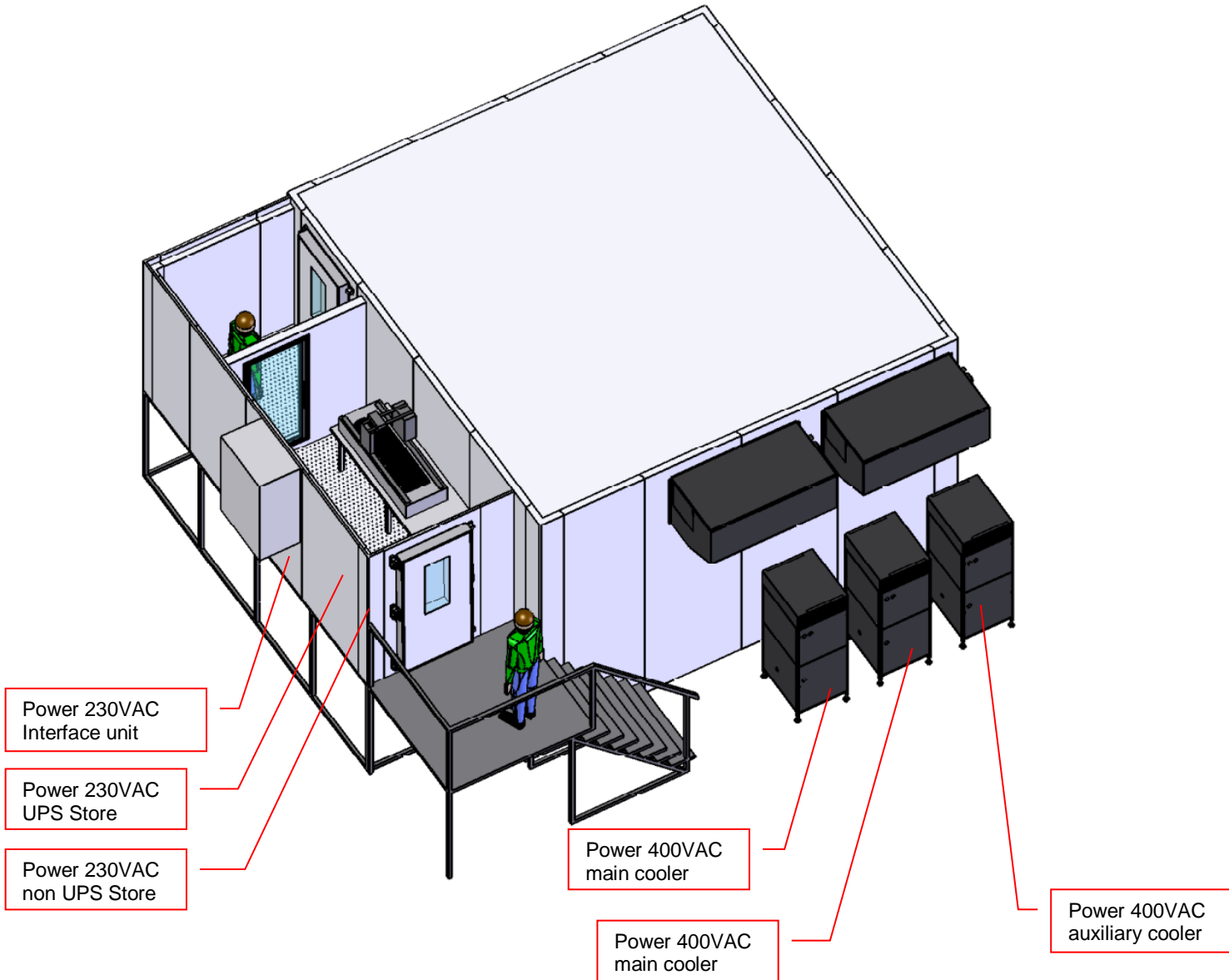

9.2 Electrical Connections Store

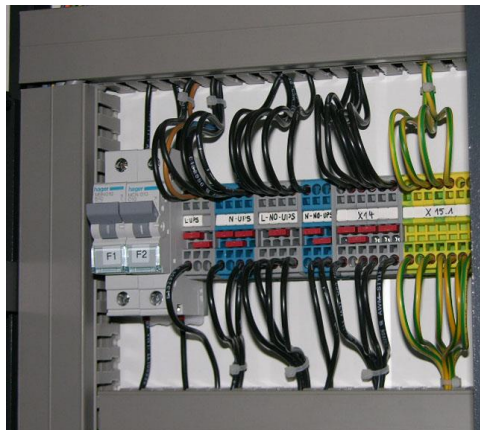

9.3 Electrical Connections Cooling units

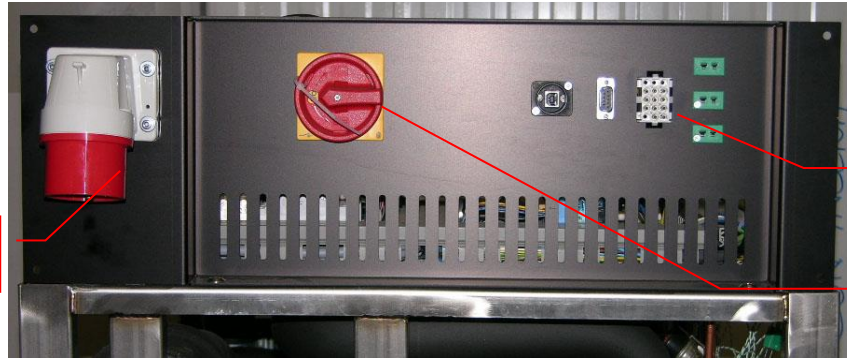

Power 400VAC cooler

Communication

Main Power switch

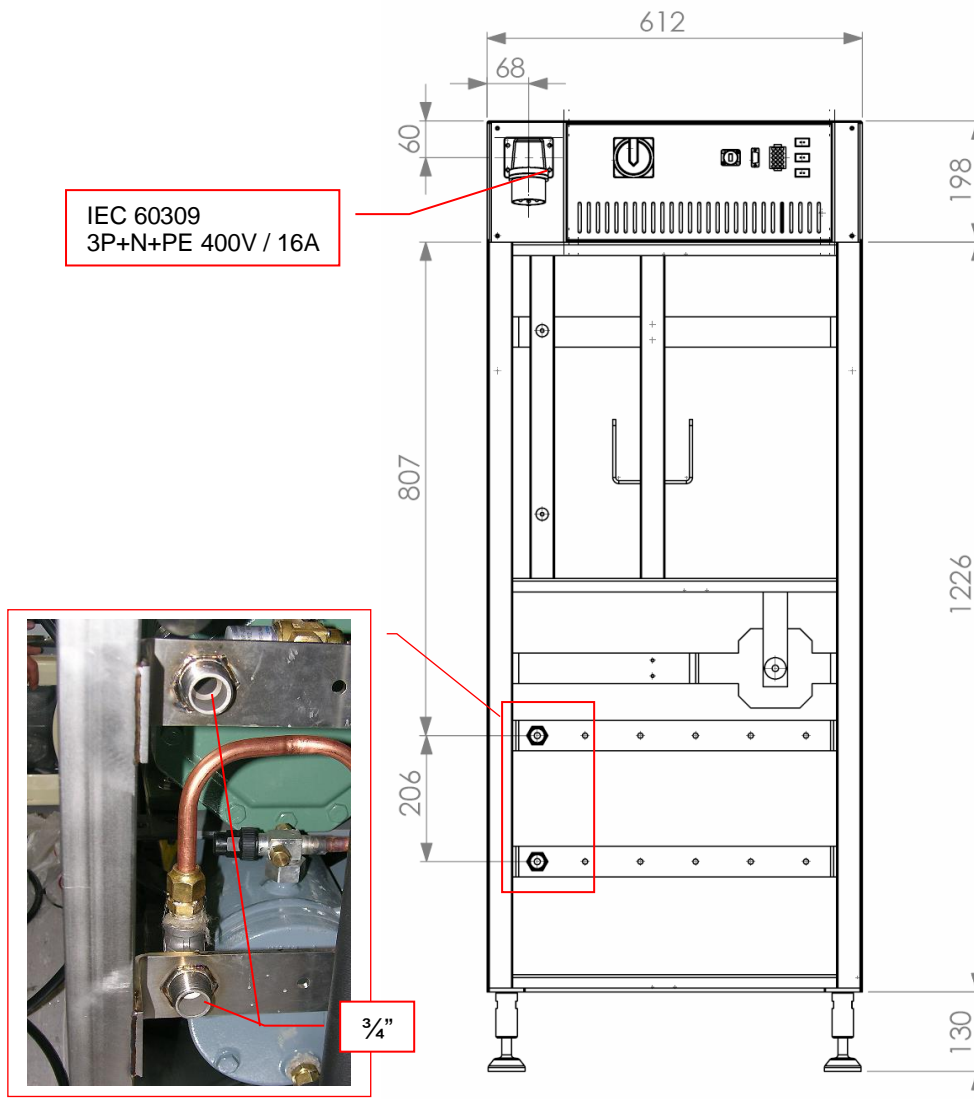

9.4 Electrical Connections Interface

9.5 Requirements

Requirement	Details
Supply Refrigeration Store	2x 380V / 50Hz 3 Phases 2x Fuse: 16A 2x Connector: CEE Type 611, 16A 5-Pol: 3xL, N, G (IEC 60309) Phase sequence: clock wise
Supply Redundant Refrigeration Store (optional)	1x 380V / 50Hz 3 Phases 1x Fuse: 16A 1x Connector: CEE Type 611, 16A 5-Pol: 3xL, N, G (IEC 60309) Phase sequence: clock wise
Power consumption Refrigeration	Typically: Current: 8 - 10 A Voltage: 380V / 50Hz 3 Phases Power: 2.5 - 6 kW
Supply Logic Control Unit Store	230V / 50Hz UPS protection Fuse: 10A Connector: Type C14, 10A 3-Pol: L, N, G
Supply Dryer Store	230V / 50Hz Fuse: 10A Connector: Type C14, 10A 3-Pol: L, N, G
Supply Interface compartment Climate	230V / 50Hz Fuse: 16A Connector: Type C20, 16A 3-Pol: L, N, G
Power consumption Logic Control Unit Store	Typically: Voltage: 230V / 50Hz Power: < 1 kW
Power consumption Dryer Store	Typically: Voltage: 230V / 50Hz Power: < 2.5 kW
Power consumption Climate Unit Interface	Typically: Voltage: 230V / 50Hz Power: < 2 kW

9.6 Gassing Installation

9.6.1 Kiwi Store Gassing and Backup Options

The Kiwi Store series supports a wide selection of gassing and backup options. Typical properties of some commonly used options are described next. There are other gassing options available. Note that each gassing and backup option is linked to specific risks and hazards. It is important to be fully informed about any specific application before installing the instrument or even running any application.

9.6.2 Safety Information

General

Commonly used in research medicine are inert gases like: Nitrogen, Argon, Helium and Carbon Dioxide. Inert gases are used mainly to create and maintain inert atmospheres for an application or process. The above gases, which generally don't react with other materials, displace oxygen in order to maintain an inert, contaminant free atmosphere.

In their liquid form these gases are very cold, (the boiling point of liquid nitrogen is -196°C) . Such cold liquids are known as cryogenic liquids, (from the Greek, kryos meaning frost and gene meaning producing). The liquid gases therefore can be used as backup cooling option in case of power failure.

Major hazards

There are some major hazards associated with these gases



WARNING !

- Inert gases are asphyxiates and will displace oxygen to produce localized oxygen deficient atmospheres
- Inert gases are odorless, colorless and tasteless
- Inert gases give no warning and may cause death in few seconds

Oxygen is the only gas, which supports life. The normal concentration in the air that we breathe is approximately 21%. If the oxygen concentration in air diminishes or, (what amounts to the same) if the concentration of inert gases increases, a situation is rapidly reached where the hazards of asphyxia become very great.

The danger occurs as soon as the oxygen levels are lower than 16%. Inert gases are odorless, colorless and tasteless and are therefore a great deal more dangerous than other gases such as chlorine, ammonia, or hydrogen sulfide, which can be detected by their odor, at very low concentrations. The asphyxiating effect of inert gases occurs without any preceding physiological signals which could alert the victim. It takes place very rapidly: just a few dozen seconds with very low oxygen content. Stated clearly "you do not notice that you are passing out!"

The danger from the inert gases such as nitrogen, argon, helium, etc cannot be stressed enough!! . Especially in this case of Asphyxia as there are no warning signs. People also vary considerably in their reactions to oxygen deficiency.



WARNING!

- In their liquid state inert gases are extremely cold fluids which can cause serious burns when in contact with the skin
- A cryogenic spill often gives a low lying cloud of vapor that creeps along the ground

When a cryogenic liquid is released into the atmosphere, it evaporates and forms a dense cloud. As it is very cold it is heavy and hangs close to the ground. So it will flow into any low lying areas, such as drains or pits. Therefore the first warning of a cryogenic spill is often given by the presence of a low lying cloud of vapor that creeps along the ground. These clouds can be dangerous, as their temperature or composition will be unknown. Visibility within the cloud is very low with the possibility of falling, perhaps into contact with the cryogenic liquid. If the cloud is nitrogen or argon then it is very likely that the cloud does not contain sufficient oxygen to support life. In this case unconsciousness could be immediate and death could follow.



CAUTION!

- When you see a cryogenic spill or a large vapor cloud notify qualified personnel immediately
- Shut off the source of liquid, by a REMOTELY controlled valve
- Do not enter a vapor cloud caused by vaporizing cryogenic liquid
- DO NOT SMOKE!

When you see a cryogenic spill or a large vapor cloud notify qualified personnel immediately. Call the Fire Department in the case of a large liquid oxygen spill. Have them stand by until the spillage is dispersed.

If possible shut off the source of liquid, by a **remotely** controlled valve if one is fitted. Do not expose yourself to the hazard, such as high oxygen, combustible or asphyxiating atmospheres or cryogenic liquid. Do not allow liquid oxygen to enter drains or sewers. If so advised, shut down any air conditioning or ventilating systems that may draw vapor or gas from the spill into other locations.

If it is essential to enter a cloud caused by nitrogen or argon (note: never enter one that could be rich in oxygen), then wear a self contained breathing apparatus provided you are trained and qualified to do so. A stand-by person, also wearing breathing apparatus must keep you under surveillance. If the release is oxygen, then your clothes could be saturated making them extremely flammable. If you suspect that you have been contaminated with oxygen do not go near any source of ignition for no less than 15 minutes. Ventilate your clothing; change if possible. A fire may occur at any time in the oxygen cloud, should it come into contact with highly combustible material.

General Safety Instructions

When working with inert gases prevent contact of liquid gas, cold vapors, or "snow" with exposed skin. Prevent entrapment of liquid in closed systems. Use only in well ventilated areas. Compressed gas cylinders contain gaseous and liquid gas at extremely high pressure and should be handled with care. Use a pressure-reducing regulator when connecting to lower pressure piping systems. Secure cylinders when in use. Never use direct flame to heat a compressed gas cylinder. Use a check valve to prevent backflow into a storage container. Avoid dragging, rolling, or sliding the cylinders, even for a short distance. Use a suitable hand truck. For additional handling recommendations on compressed gas cylinders, consult the Compressed Gas Association Pamphlet P-1.



CAUTION!

- Wear loose fitting gloves of impermeable material such as leather when working with cold liquid, solid, or vapor
- Safety glasses are recommended when handling high-pressure cylinders and in areas where vapors are discharged

Set-up gas cylinder in a well ventilated area. Keep cylinder away from sources of heat. Storage should not be in heavy traffic areas to prevent accidental knocking over or damage from passing or falling objects. Valve caps should remain on cylinders not connected for use. Segregate full and empty cylinders. Storage areas should be free of combustible material. Avoid exposure to areas where salt or other corrosive chemicals are present. Install carbon dioxide cylinders with the valve end up. See Compressed Gas Association Pamphlet P-1 for additional recommendations.

9.6.3 Installation Safety Recommendations

Preventive Measures

The very first preventive measure is to inform all persons who handle or who use inert gases:

- Of the hazard represented by the refraction of oxygen in atmosphere
- Of the preventive means to be employed in handling the gases
- Of procedures to be observed should an accident occur

This information and training should be systematically and periodically reviewed in order to maintain an awareness with regard to these hazards. In particular, training in rescue work is fundamental since quickly improvised rescue, without the respect of a strict procedure, often proves to be ineffective, if not catastrophic (the rescue worker lacking foresight becomes a second victim). An annual program of training and rescue drills is recommended.

Ventilation

Depending on the existing ventilation, amount of gas used and size of room where the unit is installed and operated, ventilation may be required. A local exhaust may be useful at the point of sources of possible gas vapors. Where low lying areas are not naturally ventilated vents should be situated to avoid higher than normal concentration. Hazards to be considered in confined spaces are:

- Limited access and exits
- Increased likelihood of gas accumulation through leaks
- Increased asphyxiation risk
- Fire and explosion hazard

To be considered as confined spaces are the inside rooms of a building, laboratory rooms, machine pits, culverts, basement trenches for piping. When working in confined spaces, it is advisable that operators and other personnel are fully aware of the hazards of oxygen deficiency and adopt the following practices:

- A fully documented permit to work system
- Personal and fixed oxygen analyzers
- Self contained breathing apparatus available for use and all personnel fully trained in its use
- Personnel harnesses and ropes
- Operation of the "buddy system"
- A system of fresh air ventilation and fume extraction

In the case of permanent presence of personnel in a room where there are risks of oxygen depletion mixture, ventilation must be maintained with at least 30m³ per hour per person. The volume of air introduced per hour must not be less than twice the enclosed space in question. Ventilation should never be carried out with pure oxygen, but solely with air.

Testing of Oxygen or Gas Content

At present, various types of oxygen analyzers are available, which are often simple and reliable to operate. Such a monitor should at least have

- A readout of the actual gas concentration
- A settable alarm threshold value
- An alarm output with an acoustic and optical alarm connected
- An error output that shows malfunction of the monitor

Ideally the monitor should be placed so that it can be read inside, as well as from outside, the room which has gas present. The selection of the type of apparatus depends on the nature of the work in the place to be monitored (temperature, multiple detectors, portable equipment, etc). The picture below shows such a monitor for CO₂.



Testing the oxygen content is desirable, although attention must be drawn to the fact that an analyzer alone is not absolute protection. Such equipment can always malfunction, unexpectedly be out of adjustment or detectors can be improperly positioned. Testing of oxygen content should therefore only be considered as an aid to the detection of a lack of oxygen.

Work Permit

For certain types of work, safety instructions and a special work procedure must be set up in the form of a work permit

Personnel Protection

Depending on the type of work to be performed, and the layout of the premises, the decision to provide additional protection for personnel may be taken on the initiative of the person in charge. Such additional protection may involve:

- The use of notices warning against the presence of a hazard
- The placing of a person on watch outside the work area
- The use of personal atmosphere monitors
- The organization of an alarm system for rapid intervention in case of an emergency
- The wearing of a harness so that the worker can be easily and rapidly taken out of an enclosed space in the case of an emergency. Preferably this harness is connected to a hoist to facilitate removing the victim. It is very difficult for one man to lift up another in the absence of a hoist.
- The wearing of an autonomous breathing mask, to the exclusion of all cartridge masks, which are ineffective in a case of lack of oxygen.
- The wearing of protective goggles and gloves when handling liquid nitrogen to avoid burns
- The wearing of all other means of protection, such as safety shoes, helmet, etc., depending on the circumstances

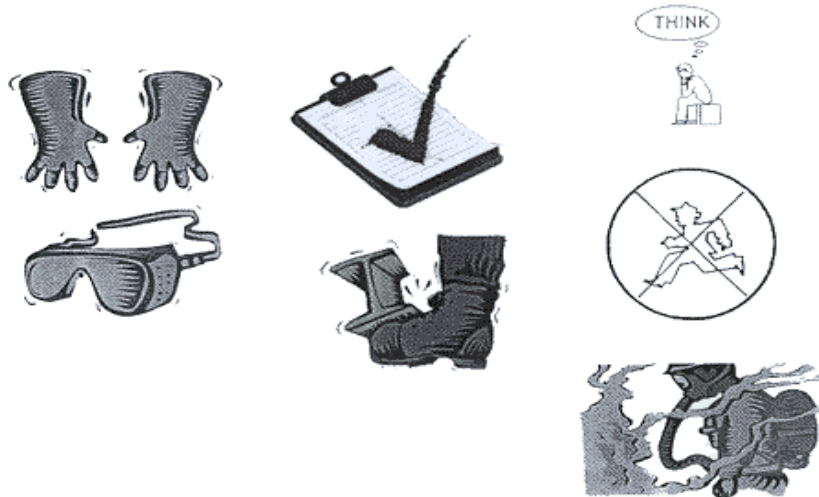

Considering the hazards mentioned above, it is essential to provide all those who handle or use inert gases with all the information and training necessary regarding safety instructions, means of prevention and procedures to be followed to avoid accidents, as well as rescue procedures to be implemented in the event of an accident.

9.6.4 Gassing System Installation

On installations preferably choose pressurized cylinders rather than gas wall outlets. The use of cylinders will limit the amount of gas being spilled in case of fatal failure. Whenever a wall outlet installation is chosen, make sure that there is a remote shut off valve installed outside the room where the gas is used.

Place the cylinder in an easily accessible and visible place next to the system. Remember that the cylinder will have to be replaced or refilled routinely. As the operator will have to check the cylinder routinely it should be clearly visible to all personnel during routine work.

The room should provide a glass door or a window that will allow a good view of the instrument and gas connection from outside the room. Often major defects can easily be detected by visible vapor clouds or icy tubes without the risk of entering a contaminated room.

Before installation make sure that the maximum specified inlet pressure is never exceeded. Always install a main shut-off valve that will cut gas flow as close to the source as possible. Secure cylinder when in use.



WARNING!

- Gas cylinders are under extremely high pressure that must be reduced for use with a StoreX incubator
- Use a pressure-reducing regulator when connecting to lower pressure piping system
- Never exceed maximum specified inlet pressure
- Never connect a Kiwi gassing inlet directly to a pressurized cylinder or wall outlet

Use a two stage pressure regulator with indicating valves. The high pressure gauge should have an indicating range of 0 to ~200 bar (0..3000 psi) to monitor the pressure of the gas source. For CO₂ a scale of 0..100 bar (0..2000psi) is sufficient. The low pressure gauge should have an indicating range of 0..4 bar (0..60 psi) and will monitor the input pressure to the Kiwi Store. A flow meter is recommended since it will show correct operation of the system.

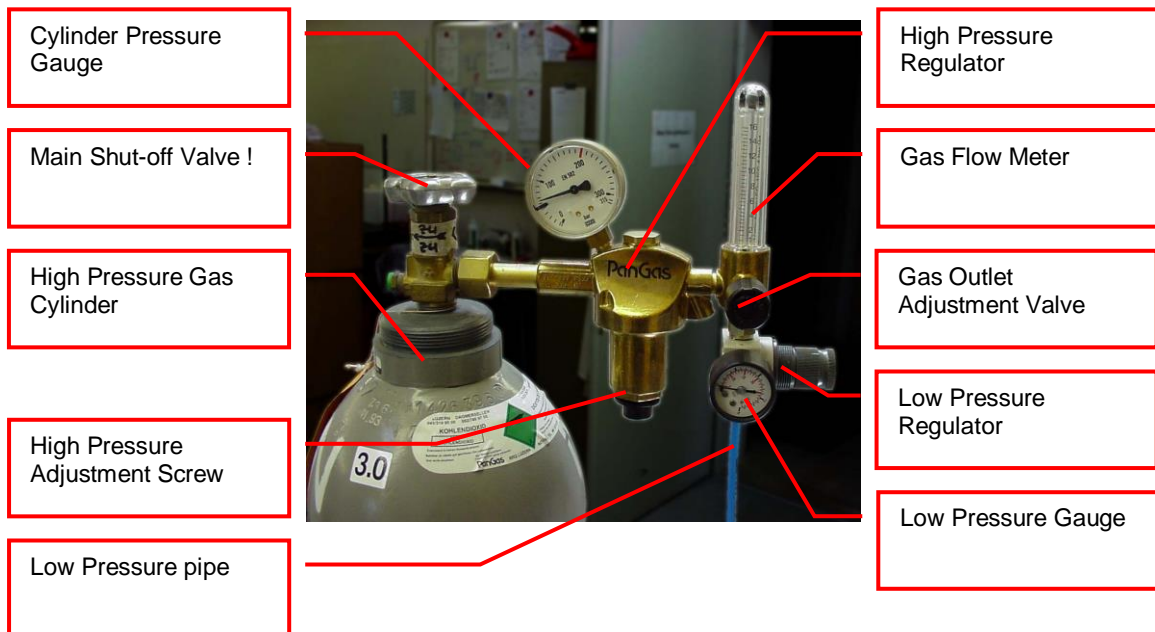

Two-stage pressure regulators are available from gas suppliers or laboratory accessories suppliers. The picture above shows an example of an installation. There is a wide variety of different models available. Your equipment may look different.

The gas inlet of the Kiwi Store is located on the back of the instrument. Attach the low pressure hose securely to the fitting. Always use the security nut. Never operate the unit without the security nut being tightly fit.

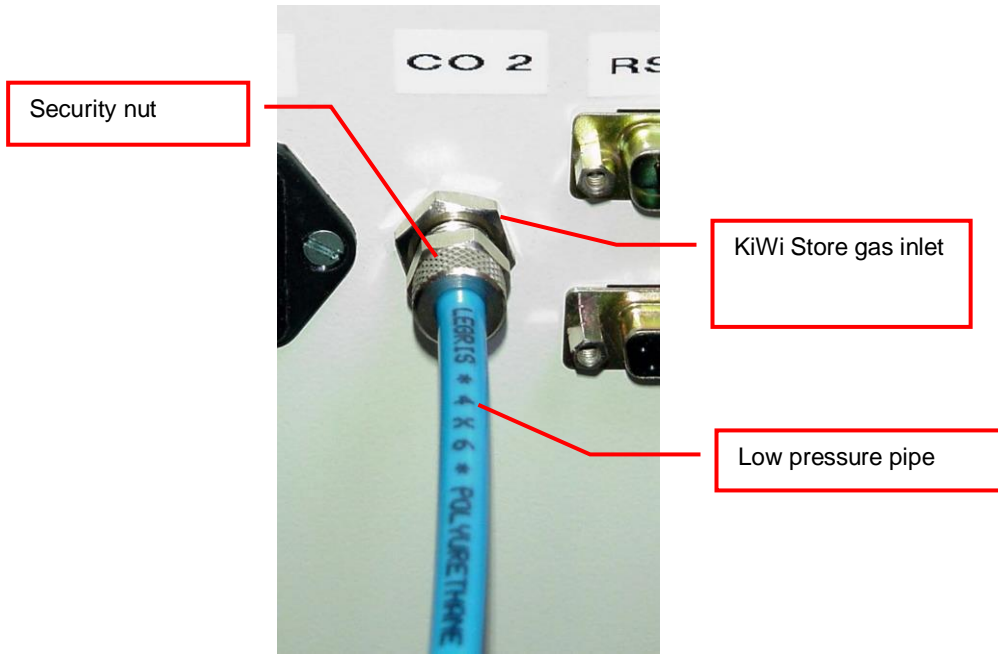

Use 4x6mm PUR, PVC, Neoprene or Nylon tube for the low pressure connection or in case of liquid nitrogen backup option a cryogenic safety tubing. Do not use Silicon or natural rubber tubing. Make the low pressure tube long enough to allow a minimum of movement of the gas cylinder for cleaning and maintenance work. For longer length of tubing, copper or other metal tubing should be considered. Foresee flexible tubing next to the instrument.

Be prepared for the following gas consumption values. These values may vary significantly over time since they depend on the instruments use.

9.6.5 Specific Advice for CO2 Carbon Dioxide

Principals of Operation

CO2 is mainly used as backup cooling for the KIWI DF STORES. CO2 allows to maintain the temperature at -20°C .



WARNING !
➤ Improper use of CO2 or improper installation of the CO2 operated equipment may cause death
➤ Read CO2 safety information and installation instructions (See CO2 Installation) carefully. If you are not familiar with the handling of CO2 and / or safety precautions contact trained personnel.

Properties of Carbon Dioxide

Carbon dioxide is colorless and odorless as gas or liquid. It is stored in containers under its own vapor pressure. If the pressure is suddenly relieved, the liquid rapidly cools as it evaporates and sublimates, forming dry ice at -78.5°C (-109.3°F)

Boiling Point @ 1 atm	-78.5°C, -109.3°F
Freezing Point @ 1 atm	-56.6°C, 76.0°F
Vapor Pressure @ 20°C	56.5 atm, 831 psi
Solubility in Water @ 20°C, 1 atm	87.8% vol.
Specific Gravity (air =1) @ 20°C, 1 atm	1.53

Health Hazard Data of Carbon Dioxide

Carbon dioxide is a minor but important constituent of the atmosphere, averaging about 0.03% or 300 ppm by volume. At higher concentrations it affects the respiratory rate. Additional symptoms are described below.



WARNING !
➤ THRESHOLD LIMIT VALUE TLV = 5'000 ppm
➤ TLV-STEL (Short Term Exposure Limit) = 15'000 ppm (=1.5% vol.)

Carbon dioxide does not support life and may produce immediately hazardous atmospheres. At a concentration in excess of 1.5%, carbon dioxide may produce hyperventilation, headaches, visual disturbances, tremor, loss of consciousness and death. Symptoms of exposure in the concentration ranges of 1.5-5% may be highly variable, but typical symptoms of carbon dioxide intoxication include the following:

CO2 Concentration	Symptoms
3-6%	Headaches, dyspnea, perspiration, breathing increases to approximately four times normal rate, symptoms of intoxication become evident, and slight choking may be felt.
6-10%	Headache, dyspnea, perspiration, tremors, visual disturbance, characteristic sharp odor noticeable, very labored breathing and ringing in the ears, judgment may be impaired, followed within minutes by loss of consciousness.
Over 10%	Unconsciousness occurs more rapidly above 10% level. Prolonged exposure to high concentrations may eventually result in death from asphyxiation.

If the concentration of carbon dioxide exceeds 10%, unconsciousness can occur without warning, preventing self-rescue. At much higher concentrations, carbon dioxide displaces the oxygen in air below levels necessary to support life.

Persons suffering from the toxic effect of carbon dioxide should be moved to areas with normal atmosphere. Self contained breathing apparatus may be necessary to prevent toxic exposure or asphyxiation of rescue workers. Assisted respiration and supplemental oxygen should be given if the victim is not breathing. Frozen tissues should be flooded or soaked with tepid water (105-115F; 41-46C). Do not use hot water. Cryogenic burns which result in blistering or deeper tissue freezing should be seen promptly by a physician.

9.6.6 Specific Advice for N2 Nitrogen

Properties of Nitrogen

Nitrogen is colorless, odorless and tasteless, as gas or liquid. It is nontoxic and non-flammable at atmospheric temperatures and pressures. A specific gravity of 0.9669 makes nitrogen slightly lighter than air. Nitrogen is mainly found in the atmosphere, where it accounts for 78.1% by volume of the air we breath. It is stored In containers under its own vapor pressure.

Boiling Point @ 1 atm	-195.8°C (-320.4°F)
Freezing Point @ 1 atm	-209.9°C (-345.8°F)
Vapor Pressure @ 20°C	150 atm
Solubility in Water @ 0°C, 1 atm	2.3% vol.
Specific Gravity (air =1) @ 20°C, 1 atm	0.97

Health Hazard Data of Nitrogen

Nitrogen is inert and does not sustain life. Nitrogen is nontoxic, but may cause suffocation by displacing the oxygen in air.

Oxygen Concentration	Symptoms
21 - 14% (<19.5%) Oxygen	Increasing pulse rate, tiredness, dizziness, drowsiness, excess salivation, diminished mental alertness
14 - 11% Oxygen	Muscular coordination slightly disturbed, intellectual performance becomes difficult, breathing and pulse rate increased
11 – 8% Oxygen	Possibility of headaches, nausea and vomiting, collapse or loss of consciousness.
< 6% Oxygen:	Unconsciousness occurs without warning and so quickly that the individuals cannot help or protect themselves. Convulsive movements, possible respiratory collapse and death or brain damage

On sudden pressure release, liquid nitrogen rapidly cools as it evaporates and sublimates, forming dry ice at extremely cold temperatures of -196°C (-320°F) at atmospheric pressure. This can cause **severe frost bite**.



WARNING !

- Nitrogen may cause suffocation by displacing the oxygen in air. Ensure levels of *at least 19.5% Oxygen*
- On evaporation Nitrogen forms dry ice at *extremely cold* temperatures of -196°C (-320°F)

Nitrogen may cause mild skin irritation, moderate eye irritation and possible gastric distress. Cause of chronic illness is not known.

On vaporization Nitrogen expands by a factor of 700; one liter of liquid nitrogen becomes 0.7 cubic meter (24.6 cubic feet) of nitrogen gas. This can cause the **explosion** of a sealed container, or it can displace oxygen in the room and cause **suffocation without warning**. Nitrogen can also become oxygen enriched and cause ordinarily noncombustible materials to burn rapidly.

In case of an accident evacuate all personnel from the affected area. Persons suffering from lack of oxygen should be removed to fresh air. If victim is not

breathing, use trained personnel to administer a supplemental oxygen supply and artificial respiration to support vital functions. If breathing is difficult, administer oxygen. Victim and rescuers must seek immediate medical attention.

Ventilate area and attempt to shut off the release of gas by tightening the main valve. If it is not possible to stop the release of gas, allow the gas to be released there. If leaking from cylinder or its valve, contact your supplier. Monitor area for a minimum of 19.5% oxygen content before allowing re-entry by personnel.

In case of frostbite, restore tissue to normal body temperature, 37°C (98.6°F), followed by protection of the injured tissue from further damage and infection. Immediately place the frostbitten part in warm water (not to exceed 40°C) or wrap affected parts gently in blankets. Under no circumstances should the water be over 44°C (112°F), nor should the frozen part be rubbed either before or after re-warming. Remove or loosen clothing that may constrict blood circulation to the frozen area. In case of massive exposure, remove clothing while showering the area with warm water. Encourage victim to gently exercise the affected part while being warmed. Call a physician. The patient should neither smoke, nor drink alcohol.

9.6.7 Principles of Operation of Gassing Options

Continuous Flow System

The Continuous Flow System is the simplest implementation of the gassing option. The use of this solution is limited to low-accuracy applications where the incubation chamber has to be filled with a specific gas or where a gas inside the chamber has to be displaced. In some applications pre-mixed gas may be used. The gas flow is adjusted to a value that generates the specified atmosphere. This value is determined experimentally by the user. In most cases the low costs of this solution will quickly be compensated by the costs caused by the excessive gas consumption and / or additional safety requirements needed in conjunction with this solution.

A pressure limiter and a flow limiter protect the system from inlet pressure fluctuations and make it relatively insensitive to the amount of input pressure. This solution is adequate for very low demanding applications and for non toxic gases. Note that a significant amount of gas may be emitted to the instrument's environment.

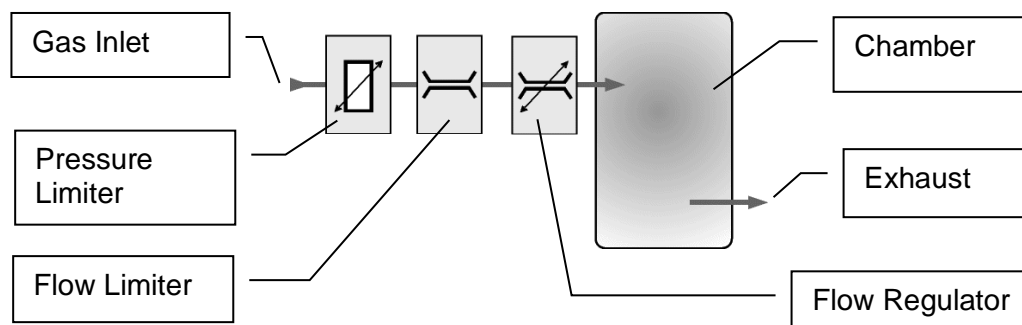

An exhaust channels the surplus amount of gas to a defined point. The exhaust is usually connected to the slightly under-pressurized exhaust system of the building. The flow regulator is combined with a visual flow indicator and a scale calibrated in l/min.

Open Loop System

The Open Loop System uses a more intelligent system that limits gas flow to the actual required amount. This solution is suitable for mid-accuracy applications where the incubation chamber has to be filled with a specific gas or where a gas has to be displaced. In applications where a certain concentration has to be maintained pre-mixed gases may be used. The advantage of this solution over the continuous flow solution is its lower gas consumption while still maintaining low costs.

The picture below explains the functioning of this system. At the gas inlet a pressure limiter and a flow limiter protect the system from inlet pressure fluctuations. This also makes the system relatively insensitive to the amount of input pressure.

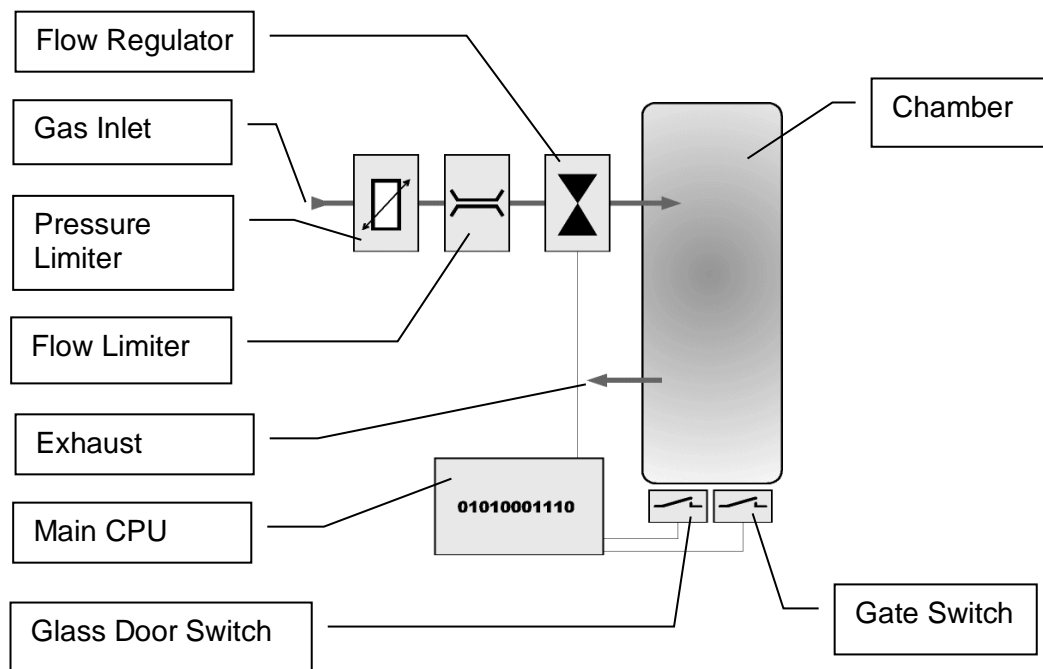

The actual gas flow is controlled by a solenoid. The solenoid is controlled by the main CPU. By sensing both, glass door switch and Gate switch, the CPU knows when there is a user access or when the Gate is opened and reacts accordingly. In fact the CPU holds three values that represent the gas needed to add. The standby value maintains the gas concentration when there is no access and compensates for minor leakages of the incubation chamber. The Gate Access Value compensates the gas loss caused by a Gate access while the User Access Constant allows recovery after opening the glass door. The CPU internally calculates the actual amount of gas needed in a specific situation. Since this system limits the gas consumption to a fairly low level the exhaust does not have to be connected in most cases.

Closed Loop System

The Closed Loop System is the most advanced system that gives a very high level of accuracy and maximum flexibility. The gas consumption is limited to the actual required amount. This solution is suitable for high-accuracy applications where the incubation chamber has to be filled with specific gas concentrations that may even vary with time. In addition this solution provides an external and remotely readable readout of the actual gas concentration inside the incubation chamber. Gas concentration can be set or altered remotely.

Right at the inlet a pressure limiter protects the successive components against overpressure, up to ~10 bar. The pressure limiter also makes the gassing option relatively insensitive to the amount of inlet pressure. A flow limiter also limits the gas flow to ~10 l/min. A solenoid controls the gas flow to the incubation chamber in accordance with the gas concentration inside the chamber.

A second tubing system measures the gas concentration inside the incubation chamber. A pump removes a small amount of gas from the incubation chamber and feeds it to the gas sensor. A particle filter protects the pump and sensor from contamination.

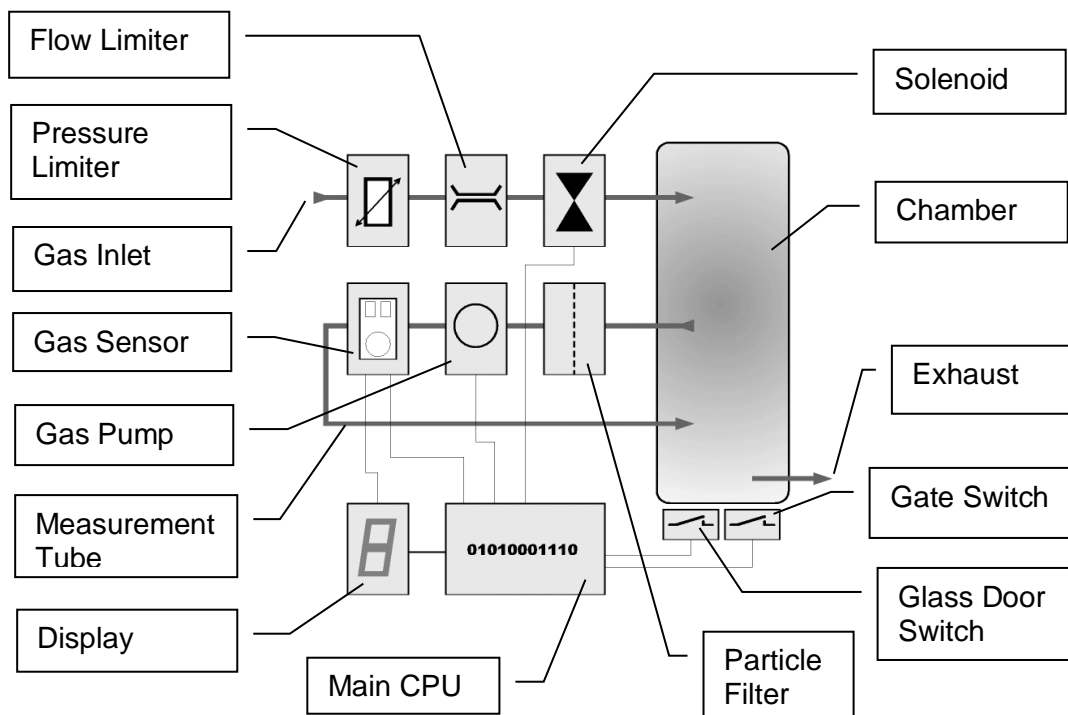

The main CPU monitors the opening of the incubation chamber preventing unwanted gas flow to the surrounding environment. The solenoid is therefore only opened when the glass door is shut and the Gate has not been opened over an excessive period of time.

9.6.8 Integrated Gassing Safety Features

There are a number of safety mechanisms implemented in the system application that protect the user from unwanted exposure to gases. Even in the case of failure or operation errors these mechanisms can ensure safe shut-off of the gas inlet. The optimum arrangement should be selected according to the level of accuracy, danger and specified settling time. The level of safety depends on the type of gassing option.

The continuous flow system has a minimal of safety functions. The exhaust limits gas leaking into the surrounding environment. A slight under pressure on the exhaust will also lower uncontrolled gas flow into the surrounding environment. The safety elements of the continuous flow system simply limit the gas flow and protect against overpressure to some extent. This system may not be used in an higher risk environment.

A significantly higher standard of safety is provided by the open loop. system. In addition to the basic flow and pressure protection, the gas flow is controlled by the system. This results in a significantly higher level of safety and in a reduction of gas consumption.

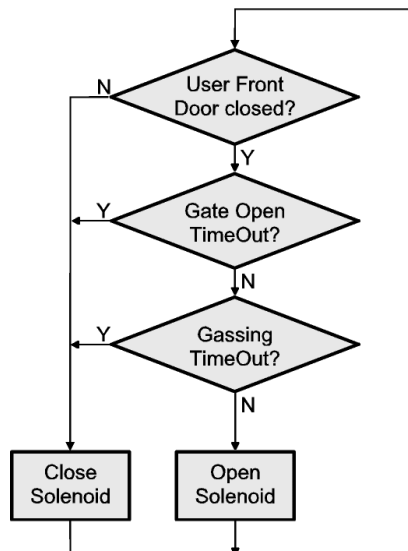

The above flowchart lists the steps that are implemented to avoid unwanted gas emissions. As a first step the gas is always shut-off when the glass door is open. This will eliminate the risk of large amounts of gas exiting when the user door is opened. The same applies to the Gate. However, because of its smaller size some gas flow is allowed even when the Gate is open. A Gate timeout is implemented cutting gas flow when the Gate has been opened for an excessive period of time. An additional general safety step is the gassing timeout. A gassing timeout will occur when the solenoid is opened over a limited period of time.

An even greater level of safety can be achieved by the closed loop system. By actually measuring and displaying the gas concentration possible errors or malfunctions can be detected by the system. If the specified gas concentration is not reached within a certain time limit the gas flow is shut-off and a error flag is set. A display will inform the operator as to the correct operation of the system.

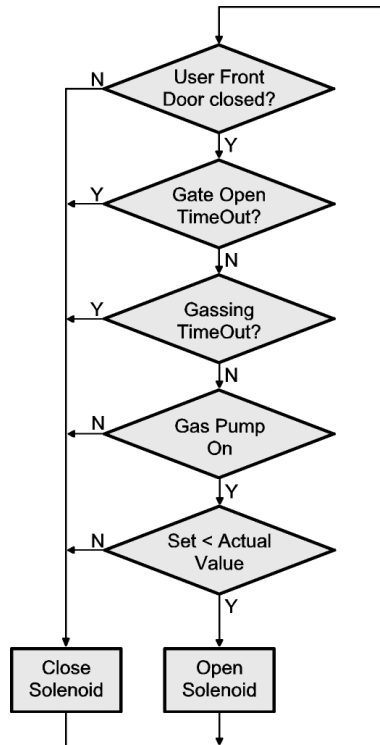

The option of remote access to the gas concentration allows a simple tracing of the gas concentration over long periods of time.

The safety features are summarized in a table given below.

Feature	Comment	F ¹	O ²	C ³
Pressure Limiter	Limits internal pressure to some extent	+	+	+
Gas Flow Limiter	Limits maximum flow avoiding full gas flow	+	+	+
Exhaust	Channels exhaust gas	+	+	- ⁴
Gas Switch	Turns gas flow on and off	-	+	+
Door Monitoring	Cuts gas flow when door opens	-	+	+
Gate Monitoring	Cuts gas flow when Gate is open over a certain period of time	-	+	+
Gas Flow Timeout	Cuts gas when a continuous gas flow occurs over a long period of time	-	+	+
Gas Flow Lookup	Controls gas flow according to system status	-	+	+
Gas Control	Controls gas flow according to measured gas concentration values	-	-	+
Gas Measuring	Gas sensor measures actual gas concentration	-	-	+
Gas Display	Gas concentration is displayed to user	-	-	+
Gas Transmission	Remote gas concentration readout	-	-	+



WARNING!

➤ Because of the high safety standards maintained within the Kiwi the highest risk of failure or unwanted gas emission lies in the external installations

¹ Continuous Flow System
² Open Loop System
³ Closed Loop System
⁴ Available on request

9.6.9 Backup Refrigeration installation

On installations preferably choose pressurized liquid gas storage cylinders rather than wall outlets. The use of cylinders will limit the amount of gas being spilled in case of fatal failure. Whenever a wall outlet installation is chosen, make sure that there is a remote shut off valve installed outside the room where the liquid is used.

Place the cylinder in an easily accessible and visible place next to the system. Remember that the cylinder will have to be replaced or refilled routinely. As the operator will have to check the cylinder routinely it should be clearly visible to all personnel during routine work.

The room should provide a glass door or a window that will allow a good view of the instrument and gas connection from outside the room. Often major defects can easily be detected by visible vapor clouds or icy tubes without the risk of entering a contaminated room. If this is not possible a oxygen level meter with a remote alarm needs to be installed creating a acoustic and optical alarm in case of low oxygen level.

Before installation make sure that the maximum specified inlet pressure is never exceeded. Always install a main shut-off valve that will cut gas flow as close to the source as possible. Secure cylinder when in use.



WARNING!

- Never operate a damaged liquid gas cylinder
- Special pressure-reducing regulator may be required to operate a liquid gas backup.
- Never exceed maximum specified cylinder pressure
- Always ensure tight fit of all connections.

Supplied connection for liquid gas backup is a 1/2" SAE male (outside thread). For liquid gas cylinder such as Cryogenic cylinders, standard connection hose are available.

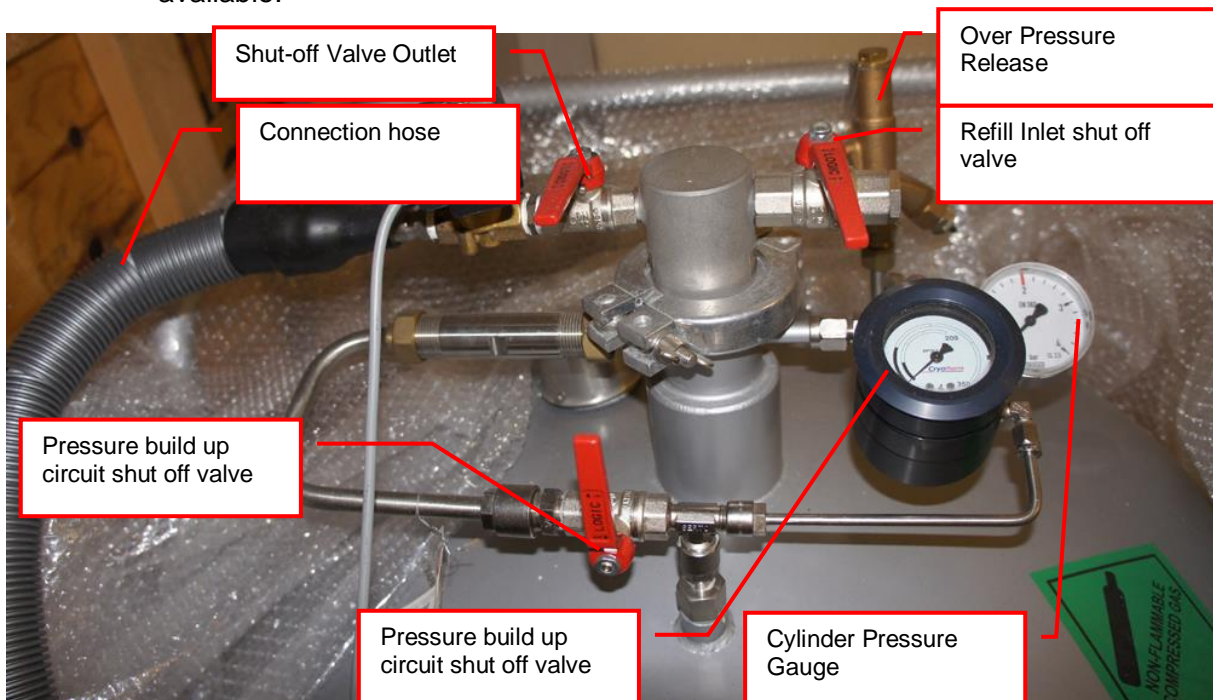

9.6.10 Specific Advice for LN2 Liquid Nitrogen

Properties of Nitrogen

Nitrogen is colorless, odorless and tasteless, as gas or liquid. It is nontoxic and non-flammable at atmospheric temperatures and pressures. A specific gravity of 0.9669 makes nitrogen slightly lighter than air. Nitrogen is mainly found in the atmosphere, where it accounts for 78.1% by volume of the air we breath. It is stored In containers under its own vapor pressure.

Boiling Point @ 1 atm	-195.8°C (-320.4°F)
Freezing Point @ 1 atm	-209.9°C (-345.8°F)
Vapor Pressure @ 20°C	150 atm
Solubility in Water @ 0°C, 1 atm	2.3% vol.
Specific Gravity (air =1) @ 20°C, 1 atm	0.97

Health Hazard Data of Nitrogen

Nitrogen is inert and does not sustain life. Nitrogen is nontoxic, but may cause suffocation by displacing the oxygen in air.

Oxygen Concentration	Symptoms
21 - 14% (<19.5%) Oxygen	Increasing pulse rate, tiredness, dizziness, drowsiness, excess salivation, diminished mental alertness
14 - 11% Oxygen	Muscular coordination slightly disturbed, intellectual performance becomes difficult, breathing and pulse rate increased
11 – 8% Oxygen	Possibility of headaches, nausea and vomiting, collapse or loss of consciousness.
< 6% Oxygen:	Unconsciousness occurs without warning and so quickly that the individuals cannot help or protect themselves. Convulsive movements, possible respiratory collapse and death or brain damage

Spills of liquid Nitrogen have extremely cold temperatures of -196°C (-320°F) at atmospheric pressure. This can cause **severe frost bite**.



WARNING !

- Nitrogen may cause suffocation by displacing the oxygen in air. Ensure levels of *at least 19.5% Oxygen*
- Liquid Nitrogen has *extremely cold* temperatures of -196°C (-320°F)

Contact with liquid Nitrogen may cause skin frost burns and severe eye damages.

On vaporization Nitrogen expands by a factor of 700; one liter of liquid nitrogen becomes 0.7 cubic meter (24.6 cubic feet) of nitrogen gas. This can cause the **explosion** of a sealed container, or it can displace oxygen in the room and cause **suffocation without warning**. Nitrogen can also become oxygen enriched and cause ordinarily noncombustible materials to burn rapidly.

In case of an accident evacuate all personnel from the affected area. Persons suffering from lack of oxygen should be removed to fresh air. If victim is not breathing, use trained personnel to administer a supplemental oxygen supply and

artificial respiration to support vital functions. If breathing is difficult, administer oxygen. Victim and rescuers must seek immediate medical attention.

Ventilate area and attempt to shut off the release of gas by tightening the main valve. If it is not possible to stop the release of gas, allow the gas to be released there. If leaking from cylinder or its valve, contact your supplier. Monitor area for a minimum of 19.5% oxygen content before allowing re-entry by personnel.

In case of frostbite, restore tissue to normal body temperature, 37°C (98.6°F), followed by protection of the injured tissue from further damage and infection. Immediately place the frostbitten part in warm water (not to exceed 40°C) or wrap affected parts gently in blankets. Under no circumstances should the water be over 44°C (112°F), nor should the frozen part be rubbed either before or after re-warming. Remove or loosen clothing that may constrict blood circulation to the frozen area. In case of massive exposure, remove clothing while showering the area with warm water. Encourage victim to gently exercise the affected part while being warmed. Call a physician. The patient should neither smoke, nor drink alcohol.

9.6.11 Refill LN2 Liquid Nitrogen cylinder

When ever working with liquid Nitrogen use of personal safety equipment is required. Thermal gloves and protective glasses have to be worn at least.

Refill interval of LN2 cylinder is depending on the required minimum backup time and the available LN2 cylinder volume. All cryogenic cylinder have a certain leakage rate which will define the time after which the minimum filling level of the tank is reached. The filling level is shown by a gauge mounted next to the connection points on the cylinder. The actual design may vary depending on cylinder manufacturer.

Before disconnecting the connection hose close the pressure builder valve, the shut off valve on the cylinder and the shut off valve on the connection point on the actual storage chamber. Use two suitable spanner to loosen the connection on the chamber (or on the cylinder depending on refill procedure). Usually the cylinder is then moved to a refill station and refilled with LN2. Depending on cylinder manufacturer the process may vary. Please refer to the manufacturers cylinder manual for further details.

To reconnect the cylinder with the system, proceed in the reverse way to the disconnecting procedure. Connect back the hose. Open the main shut off valve on the cylinder, open the shut off valve on the storage chamber and open the valve on the pressure builder. The pressure builder valve has to stay opened in order to ensure proper operation of the LN2 backup option.



WARNING!

- Wear personnel protection when disconnecting, refilling and reconnecting LN2 cylinder.
- Ensure the shut off valves are closed when disconnecting the cylinder.
- Refer to cylinder manufacture manual for exact refill procedure



CAUTION !

- Shut off valve of pressure builder has to stay open as long as the cylinder is connected to the storage.

9.6.12 Refill LCO2 Liquid CO2

The refill procedure of the CO2 backup cooling is a relatively simple process as it only needs to be performed if the CO2 cylinder is empty. As the CO2 cylinder has no loss over time it has no regular refill interval.

When replacing a cylinder, make sure the shut off valve on the CO2 cylinder and on the unit are closed. Use a spanner to disconnect the pressure regulator from the bottle. Put the new bottle in place and reconnect the pressure regulator. Open the shut off valve of the cylinder and of the storage.



WARNING!

- Ensure the shut off valves are closed when disconnecting the cylinder.

Manual Operation

10. Alert System

The KIWI STORE has a combined acoustic / visual alert system. An alert occurs when one or more abnormal statuses occur or when interaction is required. When the system is operating properly there is no alert. The various alerts are distinguished by the alert signal duration and the pause between the signals.

10.1 SAB Alerts

The storage area of the bigger KIWI STORES does not allow manual access, therefore the following alerts are defined:

Signal / Pause (time in seconds)	Alert	Comment, Action
0.1 / 2.4	No Initialization	StoreX not initialized. Press Multi Function Switch for initialization.

11. Doors

11.1 User door

The user door opens on the left side of the instrument and should be kept closed when ever possible. A spring loaded mechanism keeps the user door closed. When door is opened it should be for as short as possible periods.

In order to prevent large amount of humidity introduced into the system, the user door is heated. Note: Leaving the user door open for extended periods will cause frost and ice inside the system.

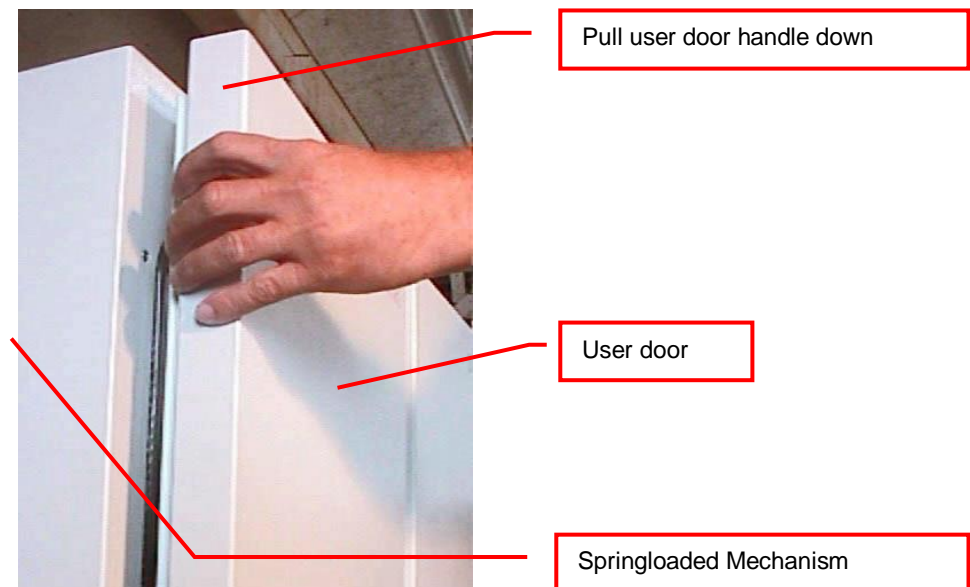

The user door is opened by pulling on the left edge or on the handlebar and may be opened to an angle of almost 180 degrees.

Regularly inspect sealing performance of the user door. The magnetic seal must keep the user door firmly closed over its whole surface. When the user door is out of alignment with the user shield it must be re-aligned by an authorized person. Note that gaps between the magnetic seal and user shield will cause undesired air exchange and therefore condensation and will degrade the temperature distribution.



CAUTION !

- Use the door handle to open user door
- Keep user door closed when it is not being accessed
- Keep user door access to a minimum
- The seal must firmly close user door
- Keep the seal clean



WARNING !

- It is dangerous to leave the user door open over long periods of time.
- Avoid excessive condensation on the glass door

12. Cassettes

Customized SAB cassettes allow simple and comfortable loading and unloading of storage samples. Once prepared, the samples can be quickly transferred into the climate chamber of the Kiwi SAB unit by means of the cassette lifts installed.

There is a wide variety of cassette types available. Make sure that you work with the proper cassette size that matches the type of plates or Cryo Boxes you are using.



CAUTION !

- Do not add, bend or remove support rails.
- If cassettes with different pitch height are used within the same system, make sure a prior removed cassette is put back in exactly the same position. Failures being generated like that, will result in destinations not found or crashes.
- Only a trained System Integrator may alter the instrument configuration and reset the lift accordingly.

The SAB cassettes (see picture below) are open at their front for loading.



To put a plate into the cassette, choose the level and slide the plate along the rails towards the back of the cassette. Slightly lift the front of the plate to avoid excessive wear of the retaining nozzles at the front end of the rails. When the plates are loaded make sure that they are all pushed towards the back of the cassette. Plates that jut out may cause collision with the handler and may result in damage to the handler.

Cassettes must be treated with great care. They are aligned within 1mm when leaving the factory. Misaligned cassettes must be returned for re-alignment. Misaligned, tilted or bent cassettes may cause handling failures. Special care must be taken when cassettes are fully loaded with plates.

Never apply force to the cassettes. Do not drop a cassette as mechanical shock will misalign it. Never lift a cassette by its side walls. This may bend the side walls of the cassette. Bent side walls cause the plates to block when being loaded or unloaded.

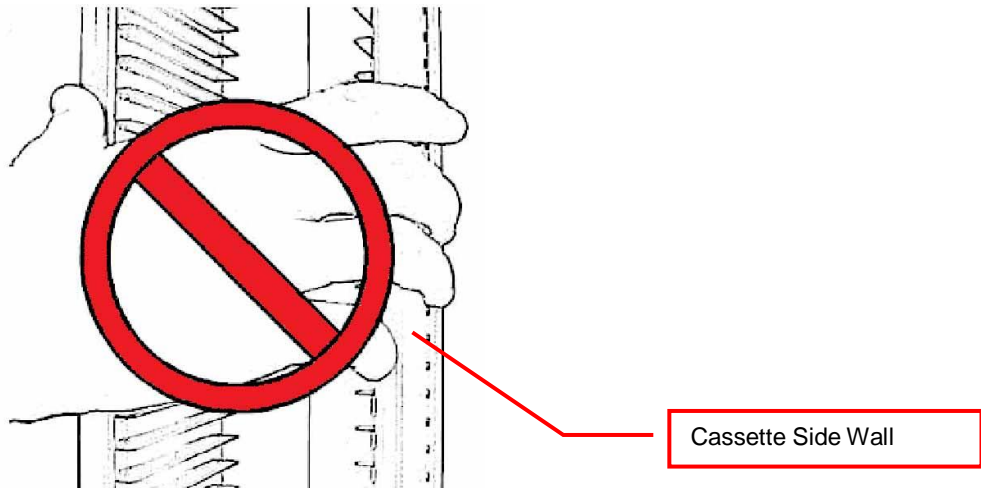

The plates / tube racks or Cryo Boxes are presented to the operator by means of the cassette lifts shown in the pictures below :



CAUTION !

- Make sure that ALL plates are pushed to the back of the cassette. Plates jutting out the front side of the cassette may cause collision with the cassette lift.
- Lift cassettes by their cassette handles only
- Do not drop cassettes. Misaligned cassettes can cause handling errors
- Do not autoclave cassettes with plastic rails. Use disinfecting solution for sterilization. All stainless steel cassettes may be autoclaved.
- Keep cassette clean. Particles and ice could prevent reliable handling.

13. Barcode Reader

13.1 Handheld 1D Scanner for plates and Cryo Boxes

A handheld Barcode Scanner for plate/rack identification is used on the Kiwi SAB Store. This one is placed in the antechamber and used when importing/exporting.

The Barcodes must be placed on the shorter side of the plates and must face towards the open side of the cassette. The barcodes should be parallel to the plate's lower edge. The barcode label should be centered both vertically and horizontally. On higher plates (e.g. deep well plates) place the barcode further down. Preferably barcode labels should be at the same height independent of the plate height. Barcode reading reliability is improved when the barcode is not covered by the plate's lid.



WARNING !

- Laser Class 2. Laser light - do not look into the beam.



DANGER !

- May be harmful to your eyes.

Use barcode testing device to verify barcode quality. Quality Class A, B or C are required. Identification of Class D is not guaranteed. For sufficient print quality use barcodes printed by thermal transfer or photographic methods. The barcode label surface should be mat and clean. Do not use yellowed, dirty or damaged barcodes.

13.2 2D Scanner / Reader for tubes

The 2D Scanner / Reader for tube identification is located in the antechamber and the loading needs to be done manually before importing / exporting material.

The 2D codes must be placed on the bottom of the tube. The 2D reader operates either on a scanner or camera based principle. If a camera is used it requires lighting by short flashes to take pictures. These flashes may be a potential trigger for people with photosensitive epilepsy.



WARNING !

- A few people may experience epileptic seizures when viewing flashing lights or patterns. Avoid watching the 2D code reading for longer time.

Use barcode testing device to verify barcode quality. The code label surface should to be mat and clean. Do not use dirty or damaged barcodes.

14. Power-On SAB

The instruments power is activated by the main switch. The instrument is turned on by pressing the power switch located at the front of the instrument. The climate portion of the instrument is activated independently. An alarm will sound. If the green light of the power switch does not turn on, check the fuse in the mains supply.

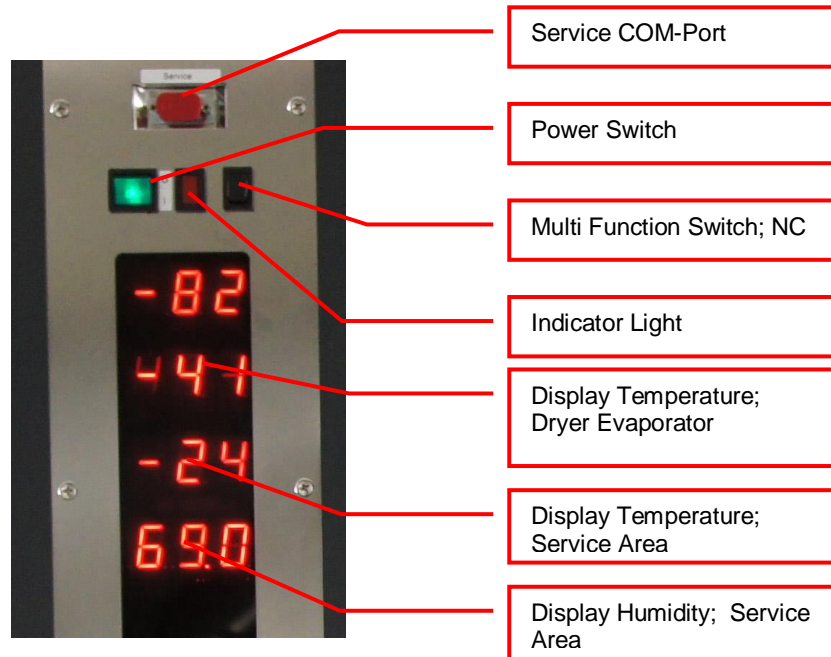

The alarm indicates that the handling is not activated. In order to activate the handling, this has to be triggered out of the controlling software.

The temperature inside the climate chamber is displayed on the temperature display. The temperature display may not be used to set temperature. The operating temperature is fixed and may not be adjusted at any time.

15. Climate Settings

15.1 Temperature Settings

System Temperature is pre set. Temperature should only be changed by a qualified system administrator or LiCONiC engineer.

15.2 Humidity Settings

Humidity is kept as low as possible and is not adjustable.

16. Cooling unit operation

16.1 Switch on cooling SAB DF

The cooling unit should stay switched on all the time. All cables should be connected before start up.

To switch on the cooling unit the main power switch needs to be turned into the position stating ON. The cooling unit will immediately start on the auxiliary cooling as the handling is not switched on. As soon as the SAB handling (and therefore the PLC controlling the climate) is switched on the main cooling will take over.

The key switch has to be in automatic position (see Picture 1).

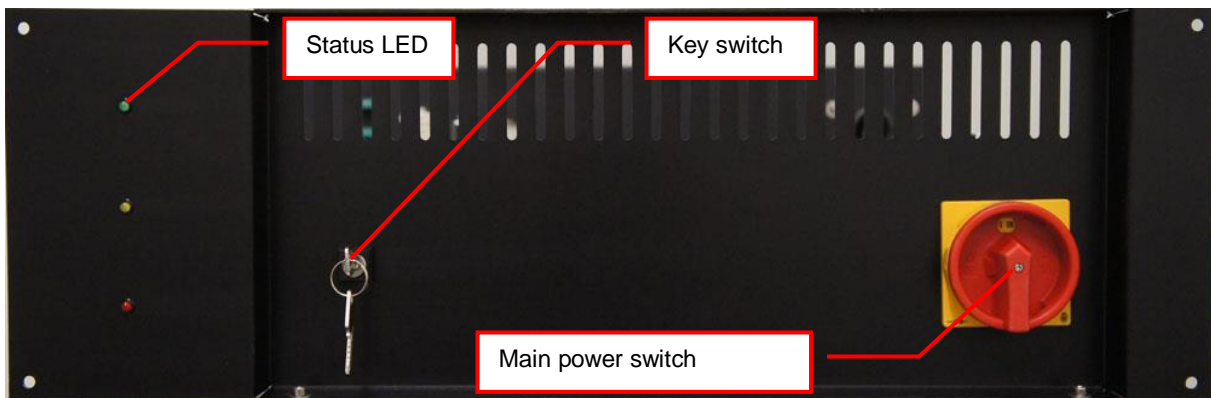

Picture 1: Cooling unit front view

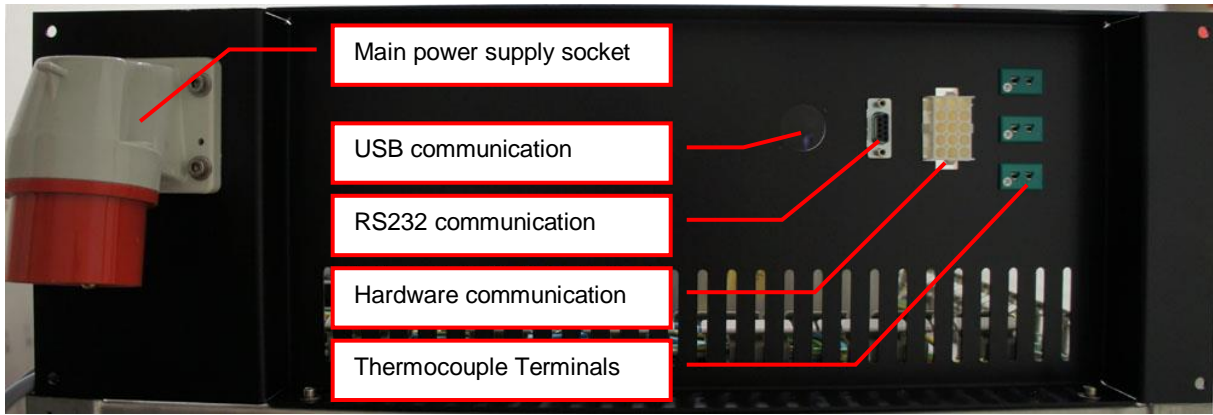

Picture 2: Cooling unit back view

Status LED	Status	Description
Green	1 st Cooling stage operating	All conditions are fulfilled to run first cooling stage
Yellow	2 nd cooling stage operating	All conditions are fulfilled to run the second cooling stage
Red	ERROR	One condition is fulfilled to trigger an error.



CAUTION !

- Do not disconnect any cables, except a LiCONiC engineer did advise to do so.
- All cooling units have to be permanently switched on.
- The key switch has to stay in automatic position.
- Ensure normal conditions (p.e.: Power and Water) before switch on the cooling units.

16.2 Switch on cooling SAB ULT

The cooling units should stay switched on all the time. Initial power up of cooling should be performed with switched off handling of store. All cables should be connected before start up.

To switch on the cooling unit the main power switch needs to be turned into the position stating ON. The key switch has to be in automatic position (see Picture 3). This has to be performed on both cooling units main and auxiliary.

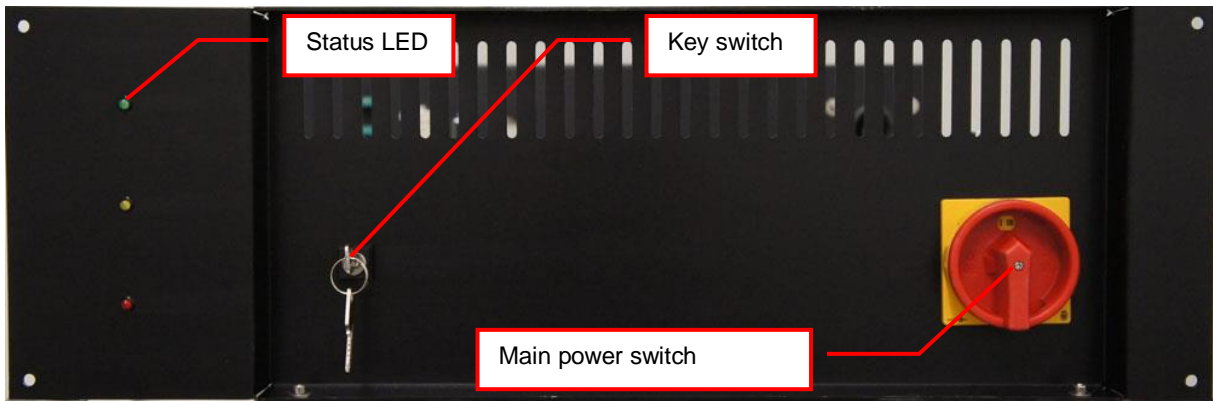

Picture 3: Cooling unit front view

The first cooling stage of the cooling unit will immediately start to operate. The green status LED therefore indicates all conditions fulfilled to run first stage. After a certain time the second cooling stage will kick in. The yellow status LED therefore indicates all conditions to operate the second stage are fulfilled.

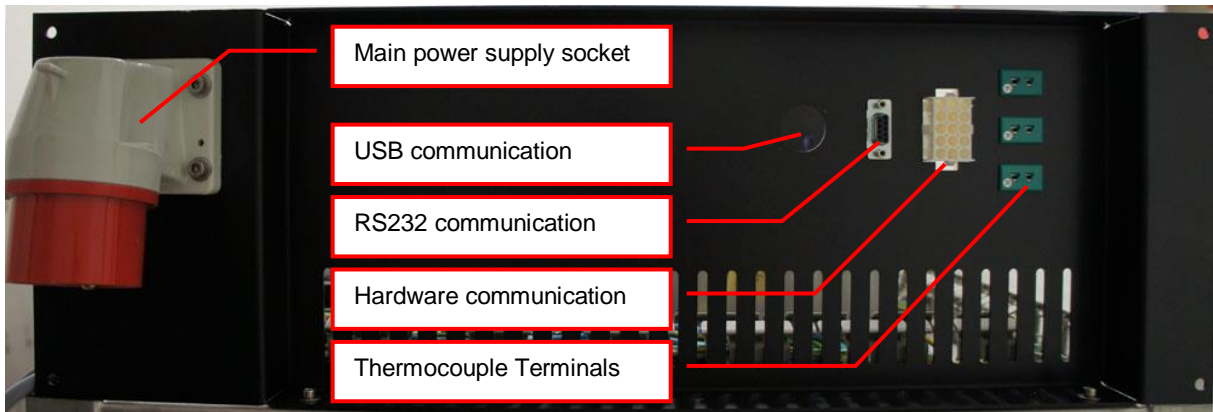

Picture 4: Cooling unit back view

In case of an error the red status LED will be lit. If the error conditions are resolved check the section “Recovery after backup activation” for the procedure to return in to normal operation.

Status LED	Status	Description
Green	1 st Cooling stage operating	All conditions are fulfilled to run first cooling stage
Yellow	2 nd cooling stage operating	All conditions are fulfilled to run the second cooling stage
Red	ERROR	One condition is fulfilled to trigger an error.



CAUTION !

- Do not disconnect any cables, except a LiCONiC engineer did advise to do so.
- All cooling units have to be permanently switched on.
- The key switch has to stay in automatic position, for normal operation.
- Ensure normal conditions (p.e.: Power and Water) before switch on the cooling units.

16.3 Recovery after Backup activation

In the case the backup cascade was activated and the system is running on one of the backup options a recovery might be necessary. The recovery procedure should only be performed after normal conditions for main cooling are restored.



CAUTION !

- Ensure normal conditions being restored to operate the main cooling
- Ask for assistance from a LiCONiC engineer in case of insecurity about normal conditions and performing the recovery procedure.
- Observe cooling after recovery. Contact immediately a LiCONiC engineer in case of repeated stop of cooling after recovery.

16.3.1 Procedure

SAB ULT System running on auxiliary cooling

- Ensure normal operation conditions being restored. Optimal reset point would be system returned to target operation Temperature.
- Toggle the key switch of main cooling (move key switch out of normal position and back again)
- Auxiliary cooling should stop now and the red alarm light of main cooling should switch off

SAB DF System running on auxiliary cooling

- Ensure normal operation conditions being restored. Optimal reset point would be system returned to target operation Temperature.
- The Error Flag 1506 has to be manually set back with “RS 1506” sent through the service terminal.

SAB ULT system running on gas backup

- Ensure normal operation conditions being restored. Power and Water for electric cooling units available.
- Toggle the key switch of aux and main cooling (move key switch out of normal position and back again)
- Either Main only or both cooling units will operated. When Target operation Temperature of the Storage is reached toggle the key switch of the main cooling again.

SAB DF system running on gas backup

- Ensure normal operation conditions being restored. Power and Water for electric cooling units available.
- As soon as normal operation conditions are restored the gas backup should stop operation an electric cooling unit takes over.

16.4 Service operation of backup cooling

In the case it is required to run the backup cooling to maintain the main cooling or perform modifications on water cooling the backup cooling may be switched on manually.



CAUTION !

- Ensure normal conditions being restored to operate the main cooling
- Ask for assistance from a LiCONiC engineer in case of insecurity about normal conditions and performing the recovery procedure.
- Observe cooling after recovery. Contact immediately a LiCONiC engineer in case of repeated stop of cooling after recovery.

16.4.1 Procedure

STC ULT backup cooling switch to manual operation

- Turn key switch into horizontal position (Manual mode)
- The first stage will switch on immediately. The second stage will kick in after about 15 minutes (yellow and green light lit)
- When Second stage is operating switch off main cooling

STC ULT restoring normal operation

- Ensure normal operation conditions being restored. Power and Water for electric cooling units available.
- Switch back on main cooling. Key switch positioned in in vertical position
- When main cooling is back into normal operation (yellow and green light lit) switch back key switch of backup cooling into horizontal position.

Contact:

Liconic AG	Main:	+423 373 63 39
Ralf Kindle (Application/Support)	Mobile:	+41 79 800 86 42
Cosmas Malin (R&D)	Mobile:	+41 79 696 95 72
Cornelis Iseli (Cooling expert)	Mobile:	+41 79 822 56 80

17. Routine Safety Checks

Carefully read all safety instructions before operating the instrument. Be sure that you fully understand their content. Although the KIWI STORE is intended to be operated as a remote controlled system, there still are some manual interactions required for operation. Apart from these operations there are also some very important safety checks the operator should be familiar with.

The operator should regularly read the display readings and check whether they match the desired values. Readings like “0.00” or “9.99”, readings that are far out, instable or that differ over long periods of time could indicate a malfunction of the instrument or could be caused by faulty settings of the system.

The electrical cables should be routinely inspected for wear, defects or contusion. There should be no mechanical tension on any cable. Broken connectors should be replaced immediately. All electrical installations should be kept clean and well protected from water and humidity.

The same applies to cables and gas tubing. They should be free of mechanical tension and should show no signs of wear or contusion. Sharp bends should be avoided under all circumstances. All fittings should be secured. Missing security nuts must be reinstalled immediately. Any broken pneumatics parts must also be replaced immediately.

The mechanical appearance of the instrument should be clean and “straight”. All movements should be smooth and precise. Watch out for unusual noises as these may indicate misalignments or mechanical wear.

Seals should close the chamber firmly. Check seals by placing a piece of paper between the seal and door. When trying to pull on the paper, there should be an even resistance. Check the seal on the glass door, gate and front door.

Condensation, mainly on the front glass door, presents a possible severe danger as it may lead to water flowing into the electrical parts of the instrument. Excessive condensation on the glass door will occur when the front door is open over a long period of time. Furthermore it may also indicate a faulty heater or high environmental humidity.

Icing on a gassing tube or on a pressurized gas cylinder indicates excessive gas flow and therefore severe danger. Once icing has been observed leave the room immediately and call for help. Do not try to locate the source of the problem or try to fix it. The room may already be contaminated.



WARNING !

- Icing on the gas cylinder or other parts of the gassing system indicate excessive gas flow.
- In the case of such icing leave the room immediately and call for help
- Do not try to locate the source of the problem or try to fix it

Software

18. Sample Management Software

18.1 Order File

The order file is used to retrieve plates or specific samples from the storage system. Two types of order files can be used to execute order jobs. The first type is the plate based export containing only 1D of plates to be retrieved. The second type does only contain the 2D code of the individual sample to be retrieved.

18.1.1 Plate retrieval

In case of the plate order file, the file is a simple list of 1D barcodes for plate orders only. These files can be passed onto the system as CSV (Comma Separated Values) file or as a TXT-File. They can be populated manually by a user or exported from MS Excel© or a database. Picture 5 below shows an example of a plate order file.

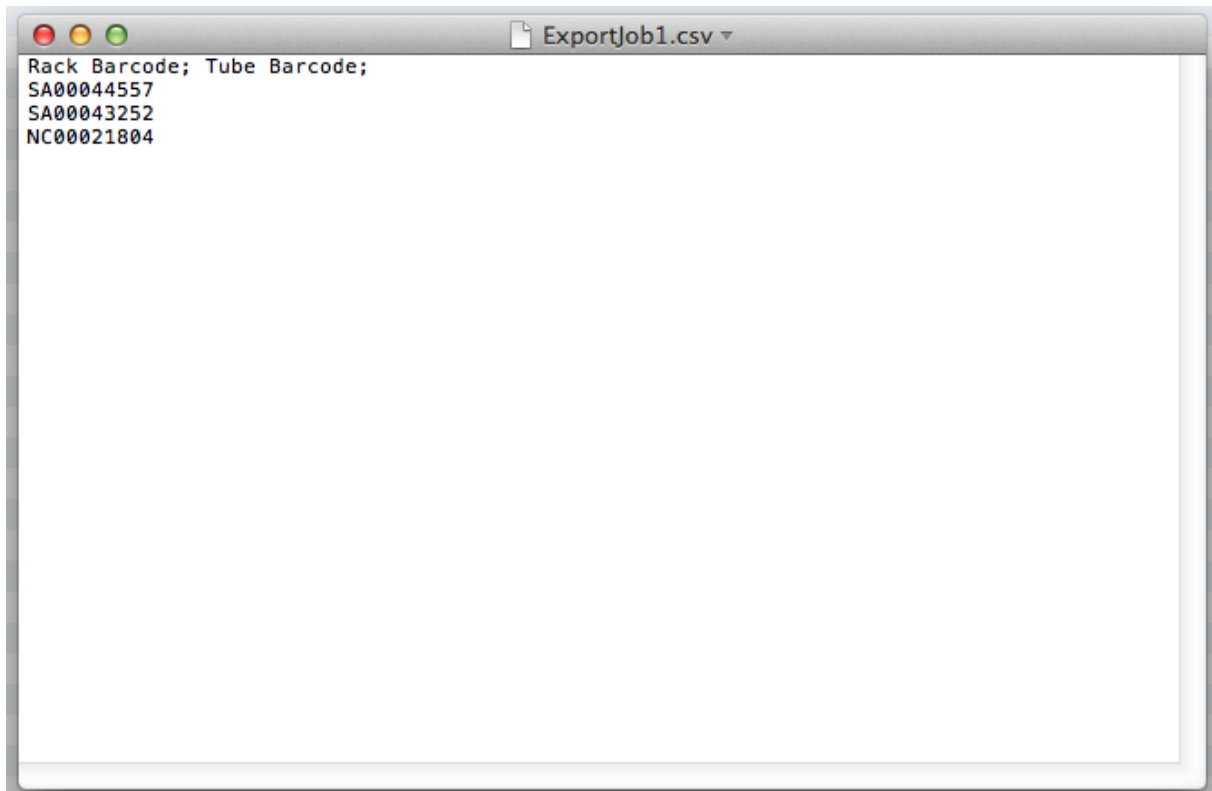

Picture 5: Sample order file

18.1.2 Sample retrieval

In case of the sample retrieval order file, the file consists of 2D codes. This file can be passed onto the system as a CSV (Comma Separated Values) file or as a TXT-File. The file can be populated manually by a user or exported from Excel® or a database too. Picture 6 below shows an example of a complex order file.

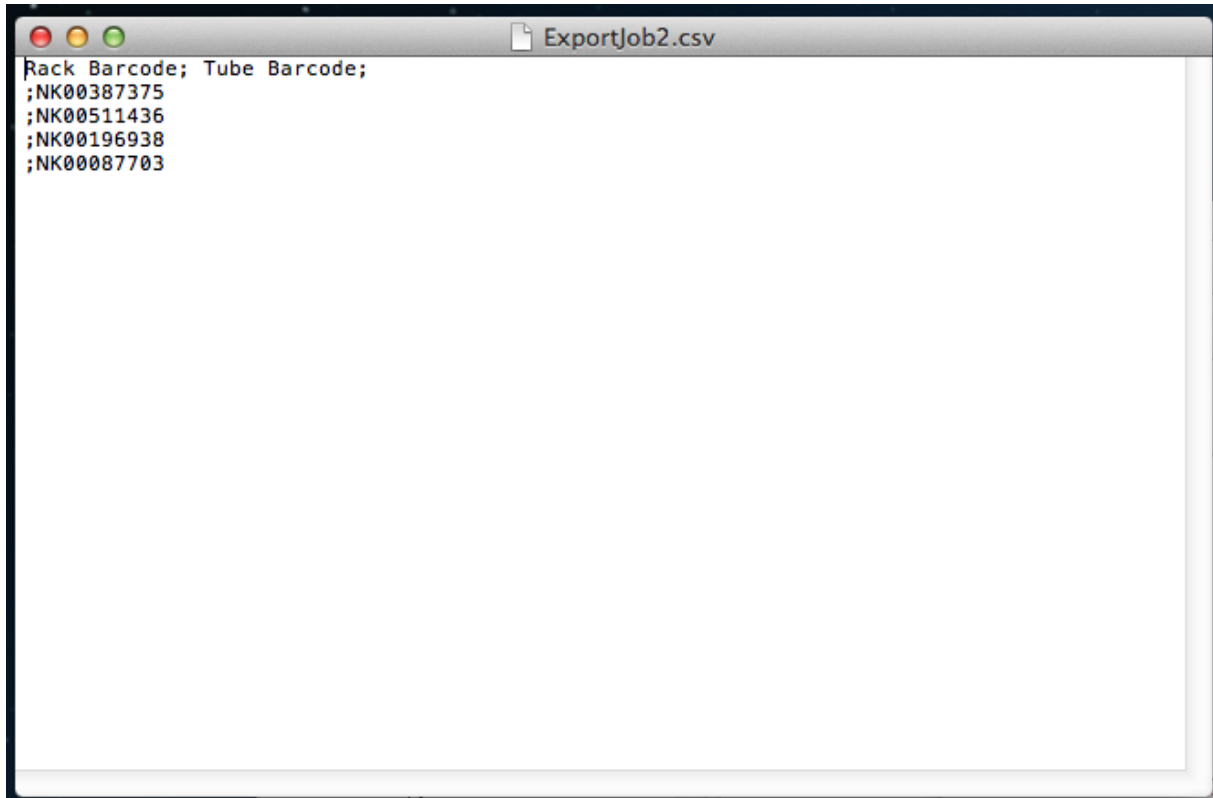

Picture 6: Sample order file

18.2 PlateExplorer

The PlateExplorer is the application to control the SAB storage system. The application is used for import and export tasks.

The PlateExplorer is a network based application and can run therefore on a remote computer over the network. Before using the application every user has to log on. (Picture 7).

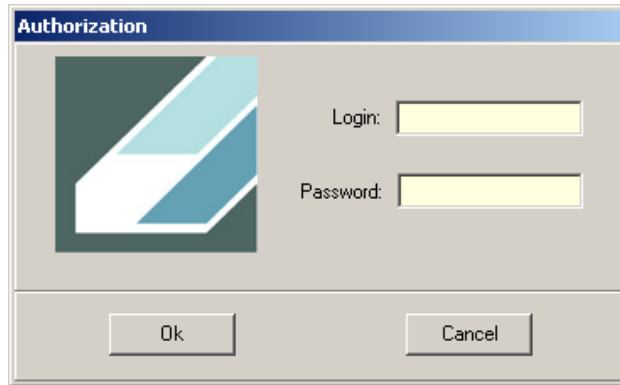

Picture 7: The PlateExplorer's login window

18.2.1 Plate content import

The physical import of plates into the system requires a certain amount of information being available prior to the storing of the samples. The data for the samples can be provided in four different ways:

- LIMS integration: A LIMS system does send or provide data of plates going to be loaded into the system.
- Reading of content: Reading the 1D code and the the 2D codes present on the plate going to be imported, prior to the import.
- A Combination of above: Is used in cases where it is necessary to confirm the physical available plate with the preloaded content.
- Specification upon import: The minimum of necessary information can be provided at the time of import. This functionality is usually used for samples in container which cannot be read with a 2D reader or where no individual sample content needs to be stored.

LIMS integration

This is customer specific. In general the data are provided in the background to the system. The individual plates will be identified with a 1D barcode scanner to identify which plates are available to be imported at the given time

Scanning of content

With a scanning application the individual plates can be scanned prior to the import process. The content is read and shown to the user to identify if the read content does comply with the physical appearance of the plate. Samples presence, readable and unreadable 2D codes are clearly marked in a visual display of the plate.

In some cases the scanning has to be performed multiple times with some cleaning steps in between to get all of the samples correctly identified.

Combination

In some cases the two ways to load content described above have to be combined. This is namely the case if samples need to be verified upon import. In this case the content is preloaded to the system but still scanned to confirm the physical plate does correspond with the expected. If there is a discrepancy between the physical present to the data the user will be notified. The then following behavior of the system has to be individually decided.

Definition upon import

If the content of individual plates is not of importance and the plates are only handled as a whole, the minimal necessary information can be provided up on the time of import. The most important information is the sample type and the 1D code. The 1D code can be read with a scanner but the sample type has to be provided. The sample type is needed to identify the correct storage position suitable for the particular sample type.

18.2.2 Import

The import of plates is executed within PlateExplorer. Plates which have been preloaded to the system for being imported can be stored within the system. The import is triggered by pressing the import button in Plate Explorer:



After pressing the import button the below window is shown. It does display the preloaded plates waiting for import. The plates are shown on the left.

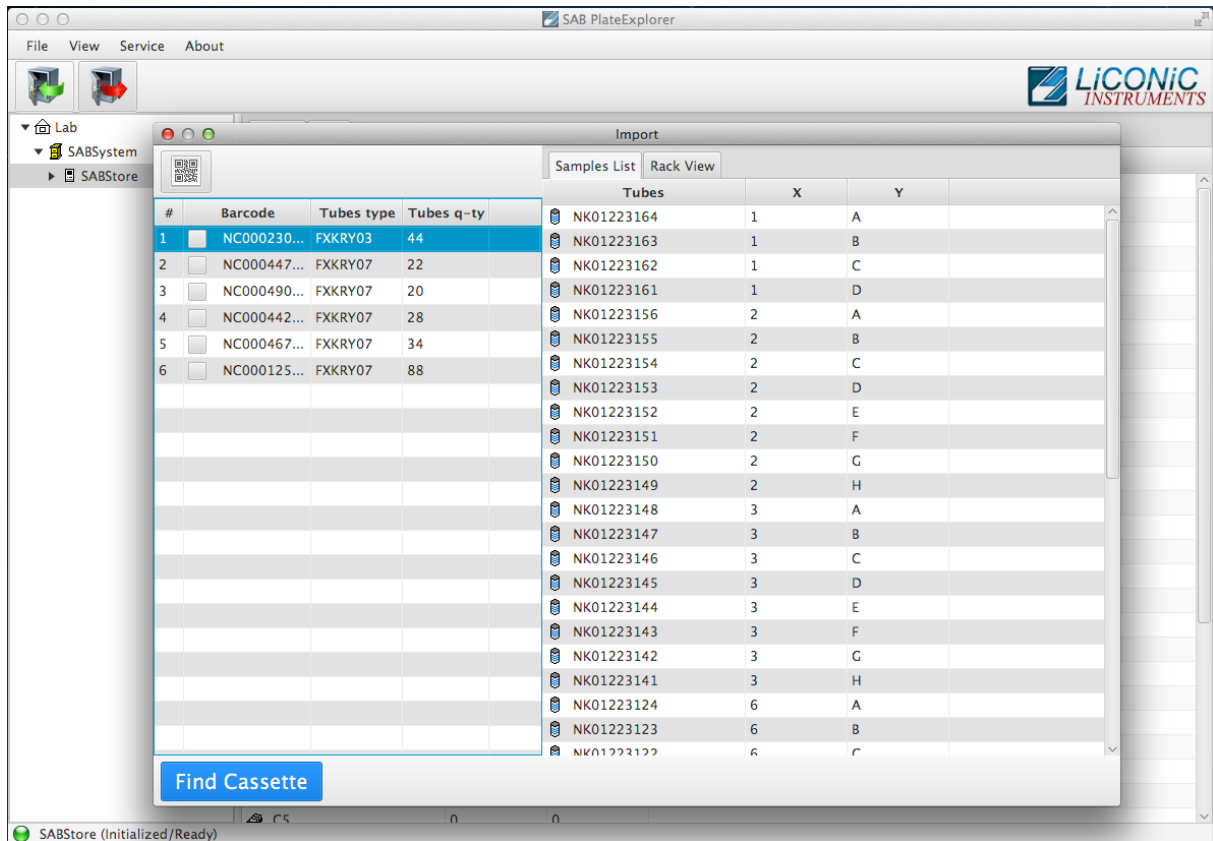

Picture 8: Import screen 1, preloaded content

The plates to be loaded are selected by ticking the check box. The system will expect these plates for loading and will not accept any other plate.

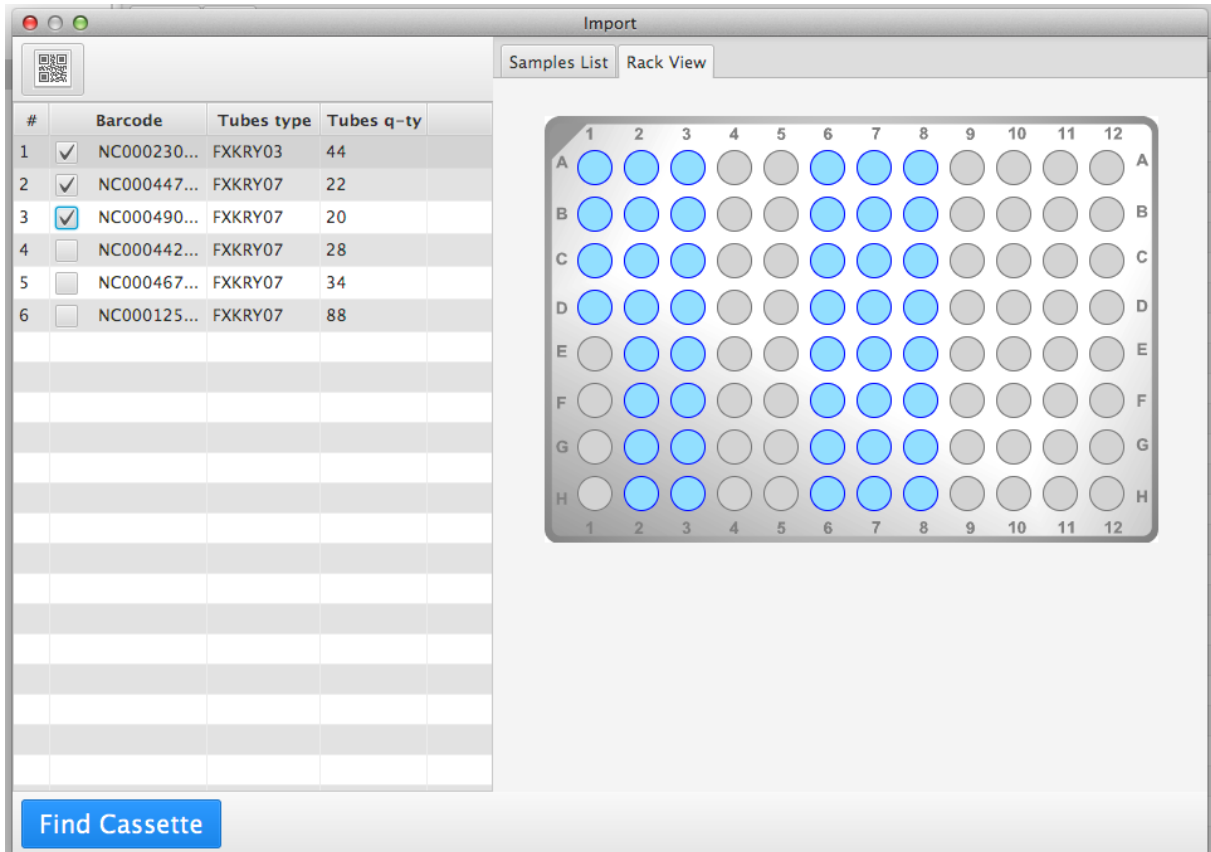

Picture 9: Plates selected for import

To confirm the selection of plates the “Find Cassette” button is pressed. The system will display cassettes suitable for the selected plates. One of the suitable cassettes is selected.

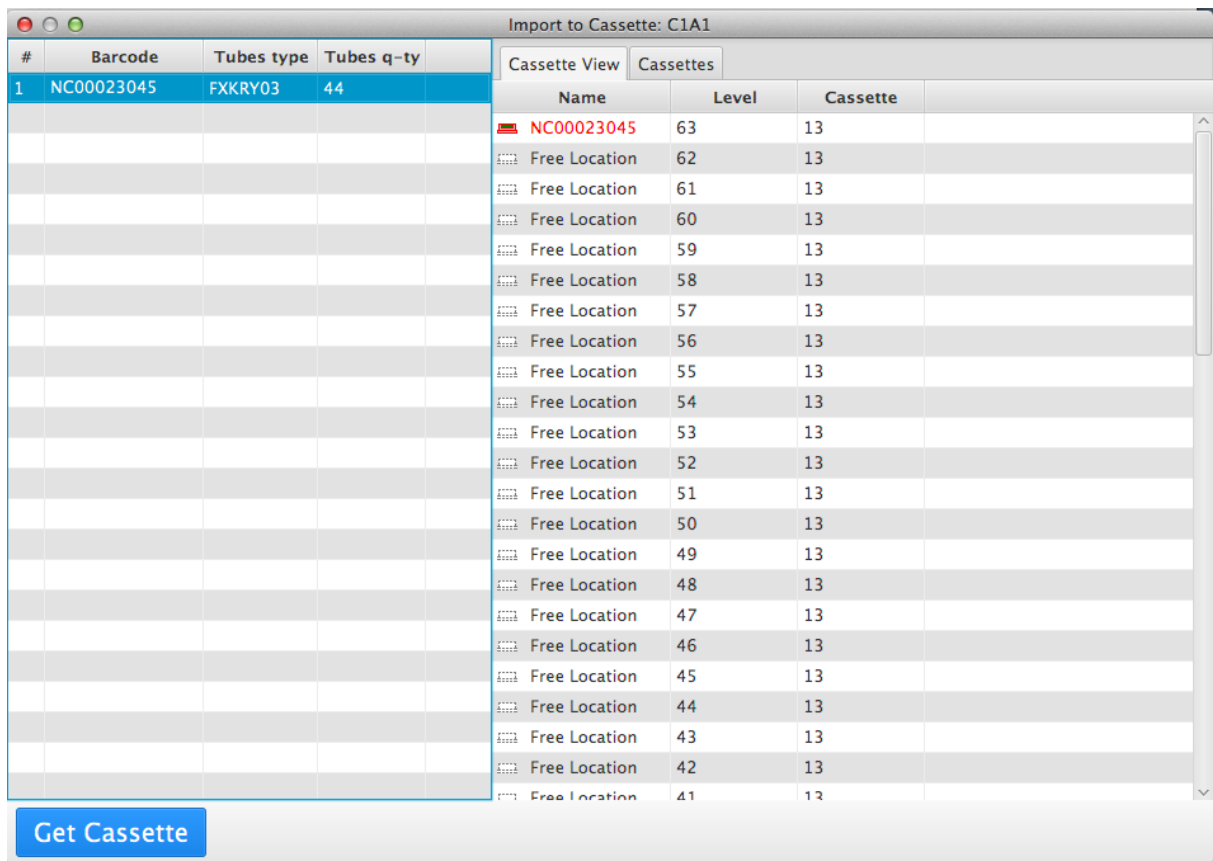

Picture 11: Plate set to available free location

With the “Get Cassette” button the placement of the plates is confirmed and the cassette is presented to the user.

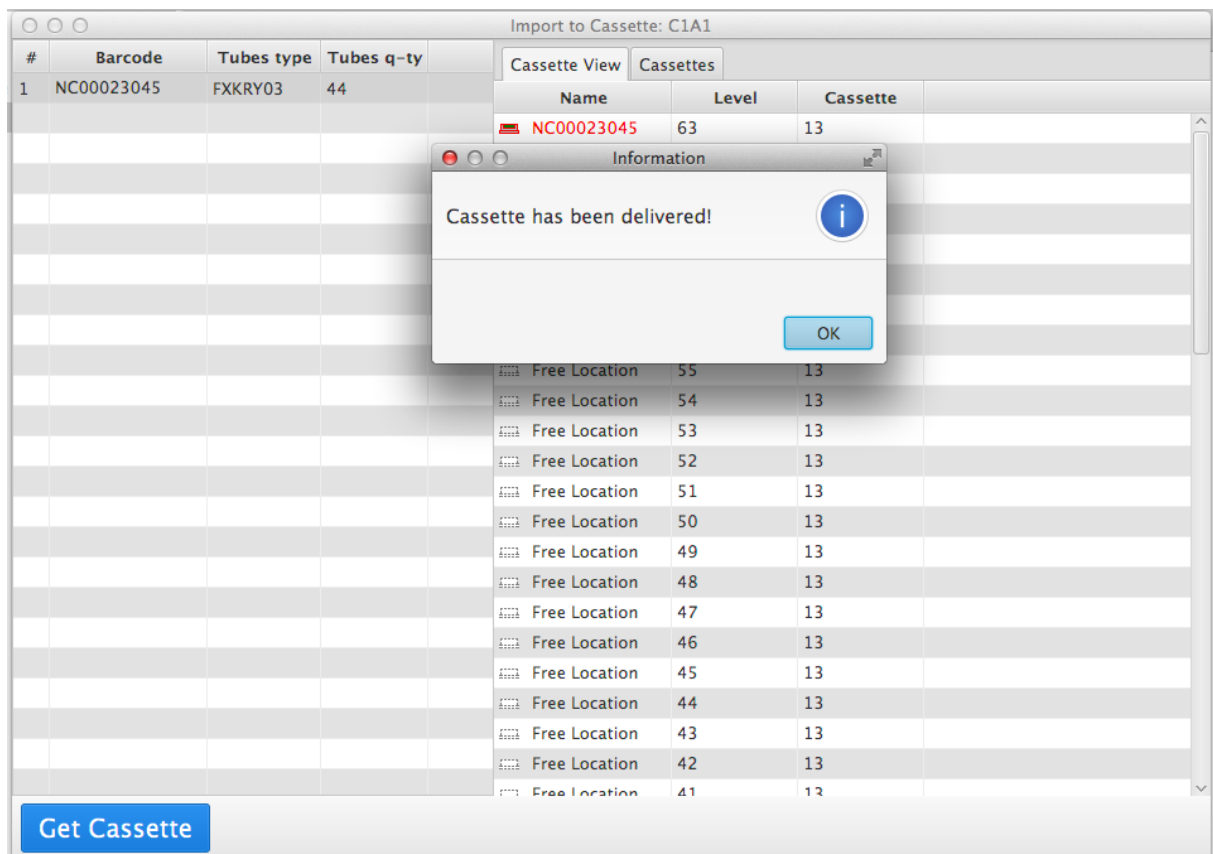

Picture 12: Confirmation of cassette delivery

The plates now are moved manually into the cassette and the loading of the cassette is confirmed by reading the 1D barcode of the plate. Correctly imported plates are displayed with a green hook.

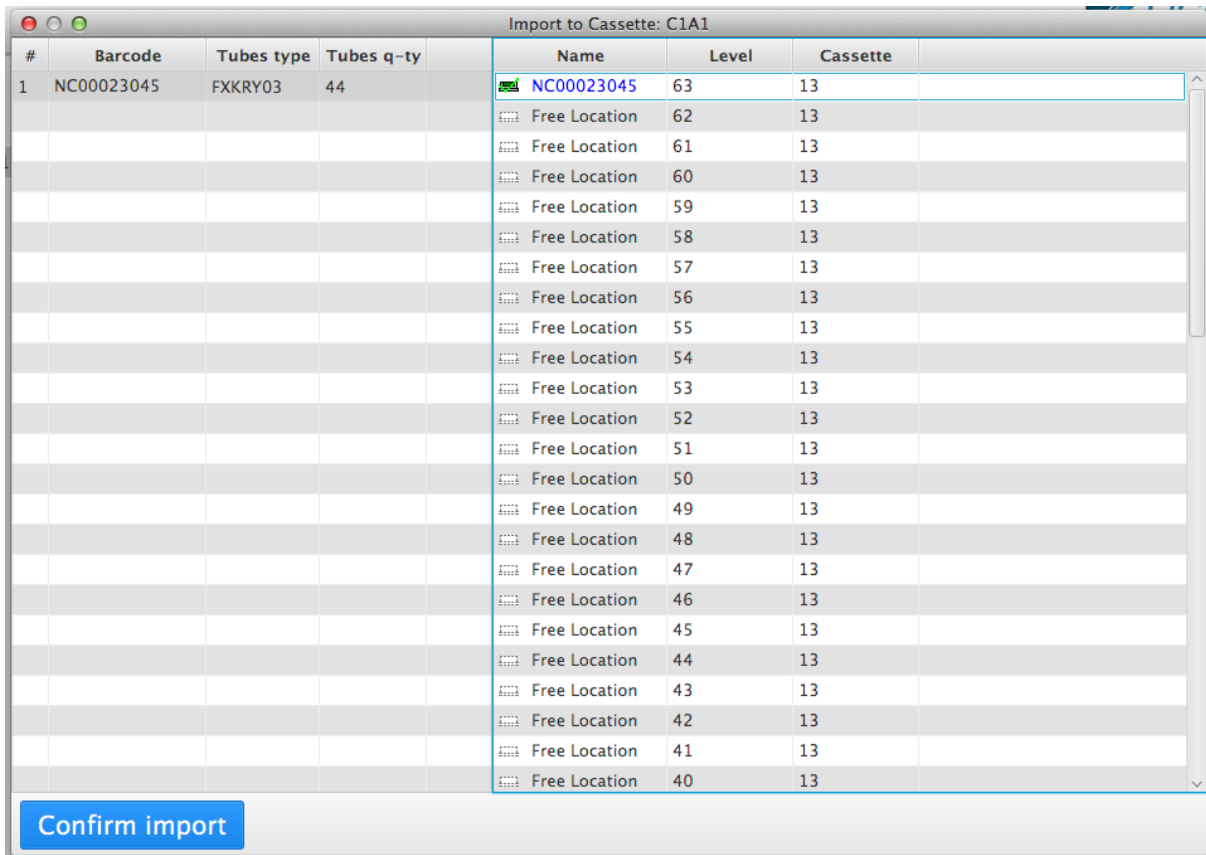

Picture 13: Confirmed plate in cassette

After all plates have been successfully loaded to the cassette, the import is confirmed with a push to the “Confirm Import” button. The cassette is transferred back to the storage

18.2.3 Export

The export of plates and samples is executed within PlateExplorer. Plates which have samples on them or are requested as a whole can be exported from the system. The export is triggered by pressing the export button in Plate Explorer:



After pressing the export button the export is started. Depending on the integration the plate overview is immediately displayed or the job selection is opened. In the job selection the job is searched on the computer and sent to the system. After this also the plate overview is shown.

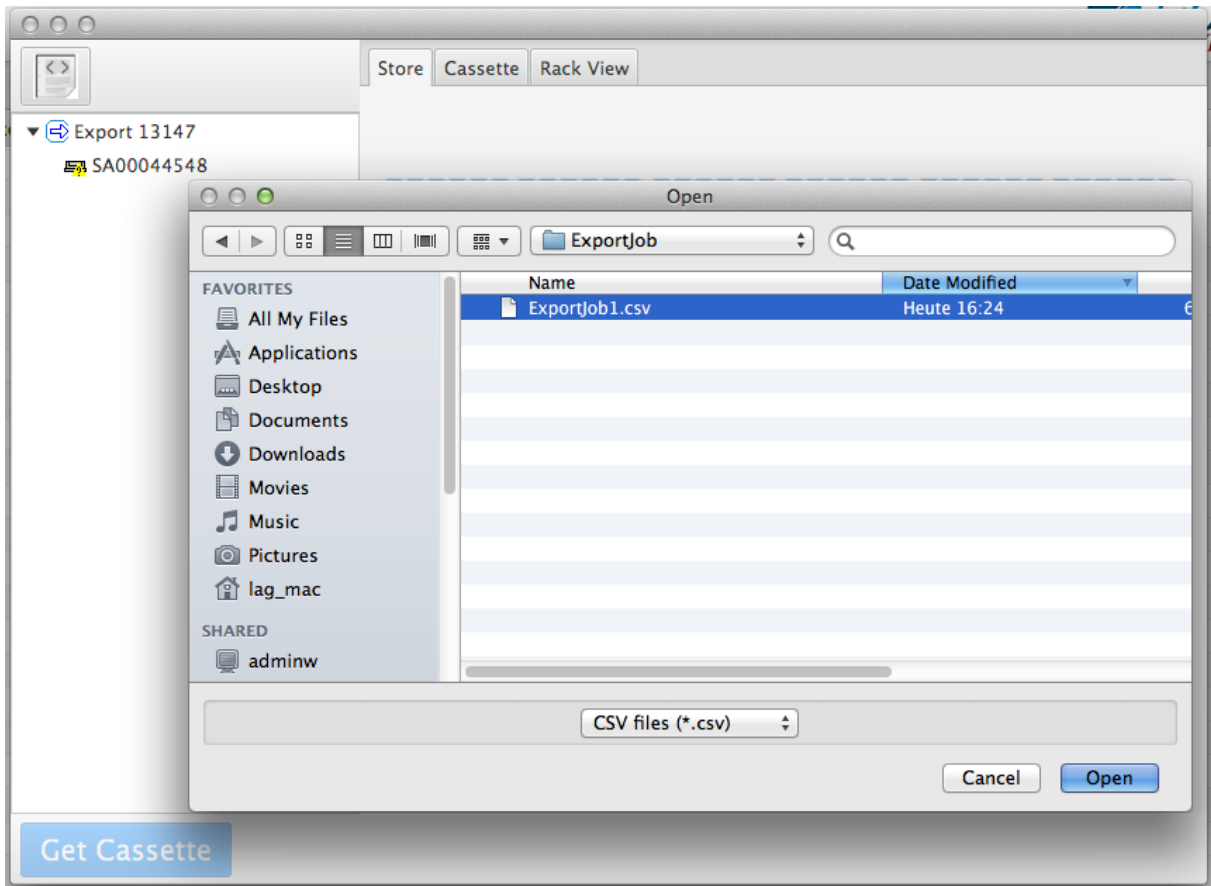

Picture 14: Selecting a job file

The job overview does display the involved cassettes and plates/samples.

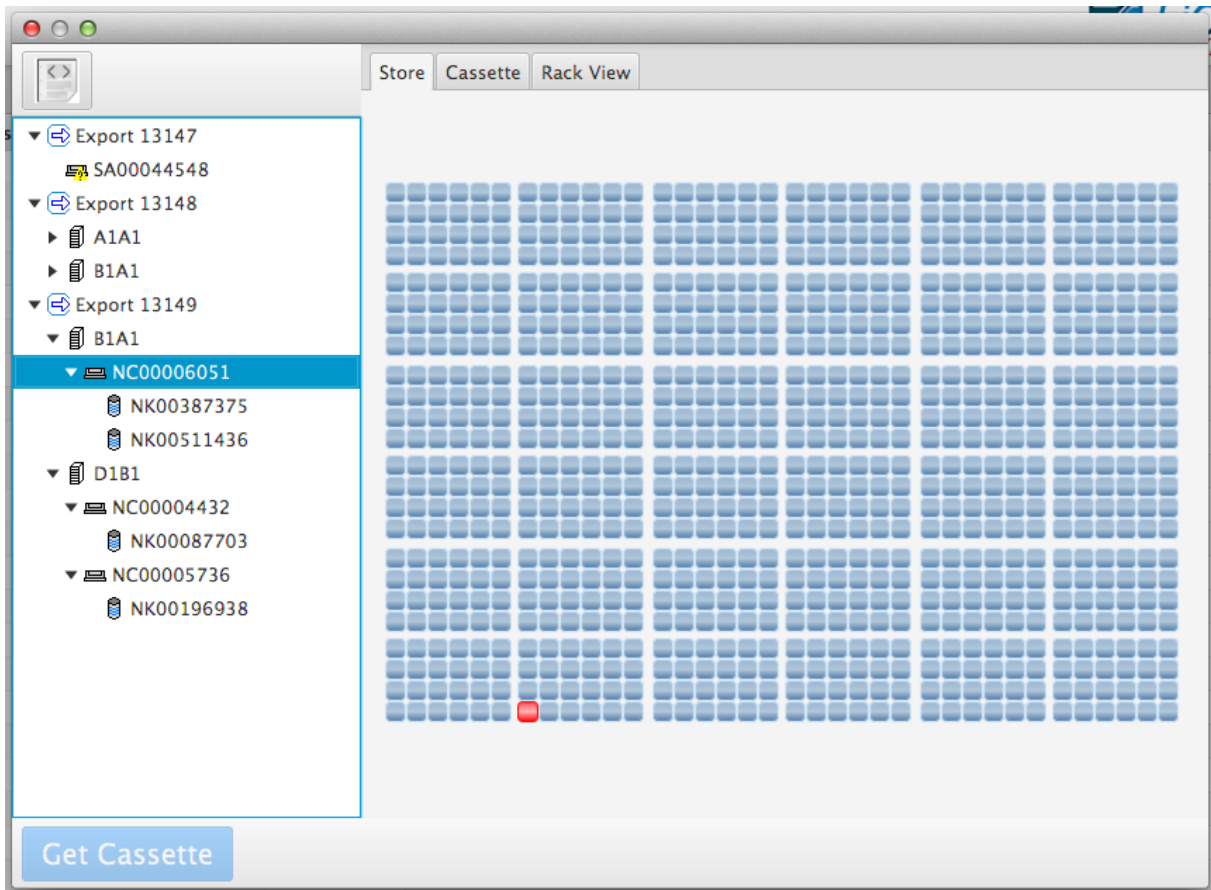

Picture 15. Job Overview

By selecting the individual cassette or the individual the respective location of the requested sample or plate is displayed.

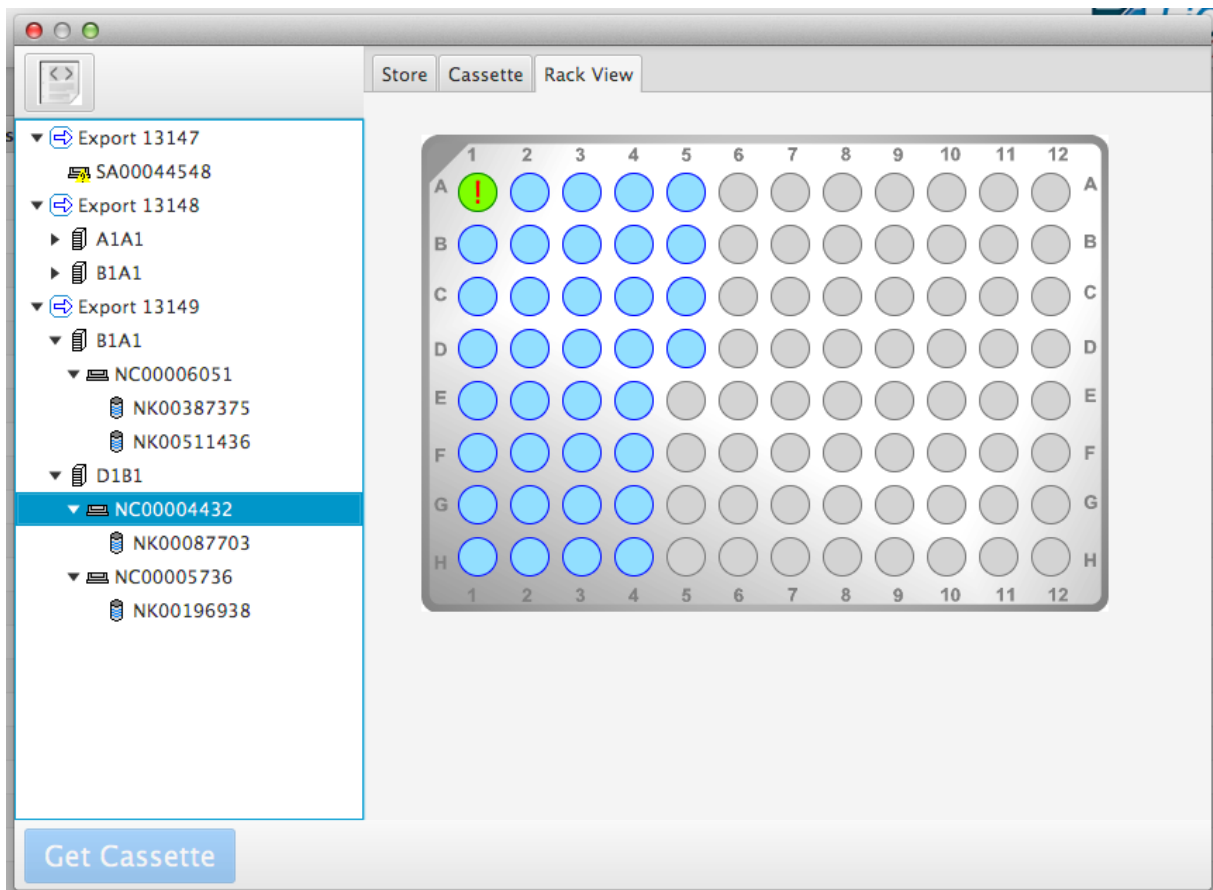

Picture 16: Display of requested sample

By pushing the button “Get Cassette” the relevant cassette is presented to the user. With the 1D hand scanner the correct palate is confirmed. If whole plate is exported this is removed from the system. Are only individual samples are requested, the sample is removed from the plate and the plate returned to the cassette. After the export of plates and samples has been finished the export is finished by pushing the button “Confirm Export”. The plates are removed from the cassette and the cassette is returned to the storage.

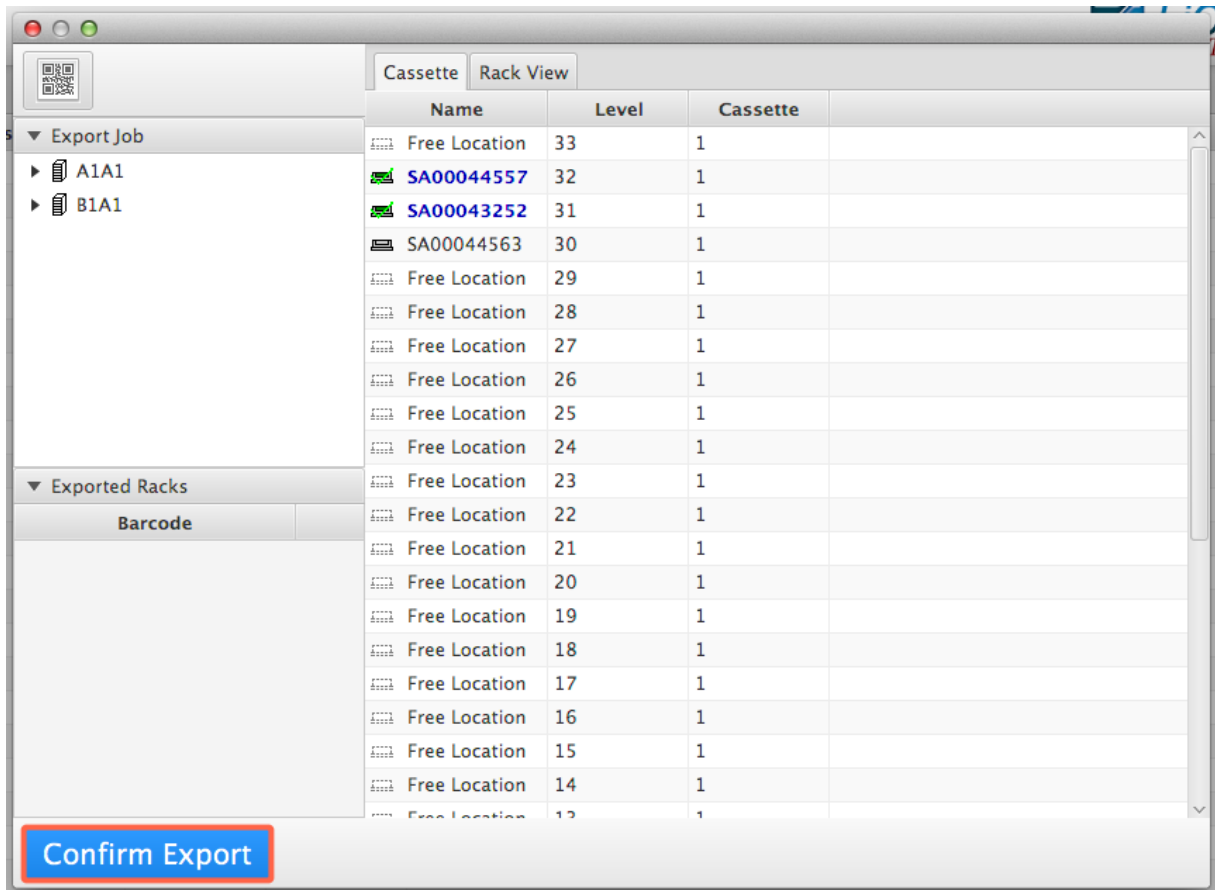

Picture 17: Display of correct plates

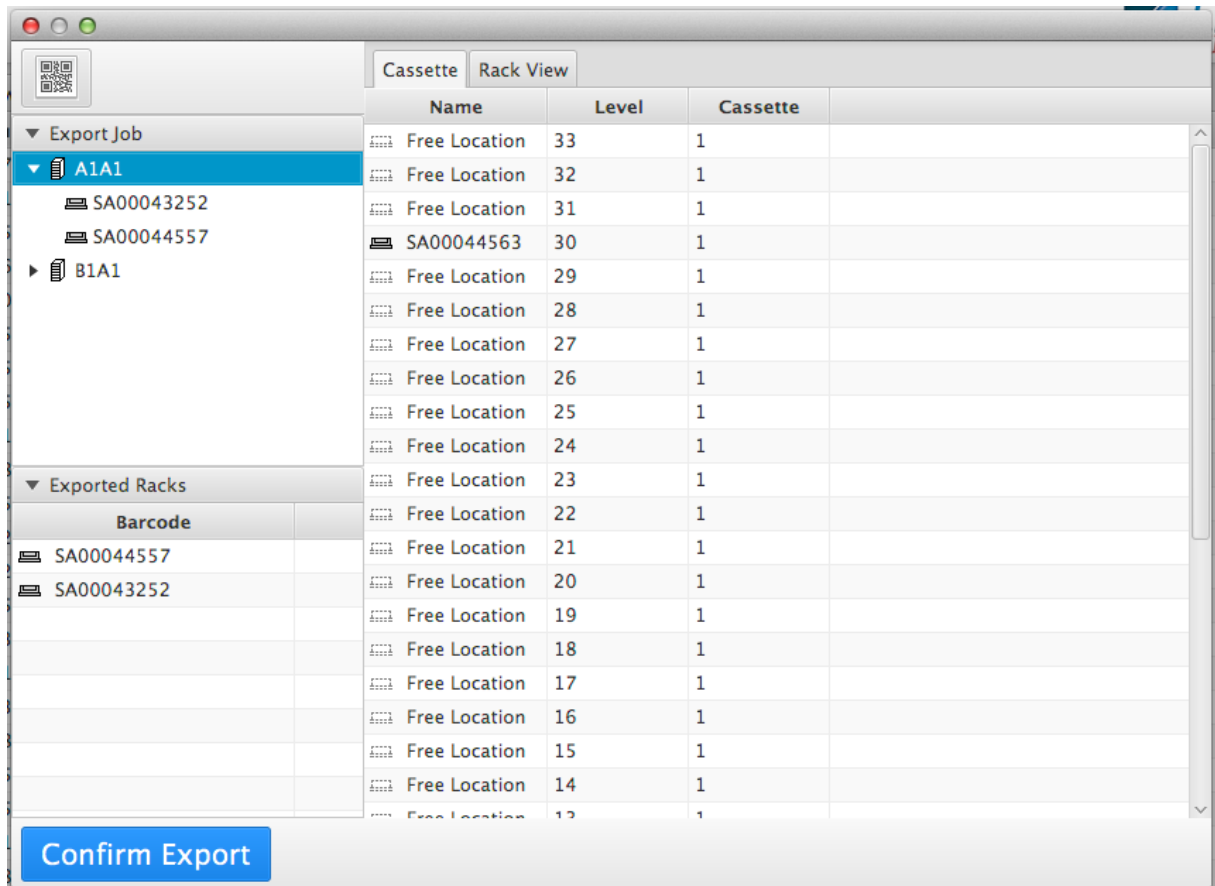

Picture 18: Plates removed from system

18.2.4 Manual Operations

In this chapter the functionality accessible to the administrator and the normal user are described. There is only one difference between user and administrator. Whilst the user has only access to the assigned area, the administrator has access to the full store. Therefore the difference will not be mentioned in this part of the manual anymore.

Get / Set Cassette

The **Get and Set Cassette** functionality of the PlateExplorer is used to retrieve and return cassettes into the store manually. To access the commands select a cassette with a left click and perform a right click. A context menu with the Get Cassette and the Set Cassette commands are presented.

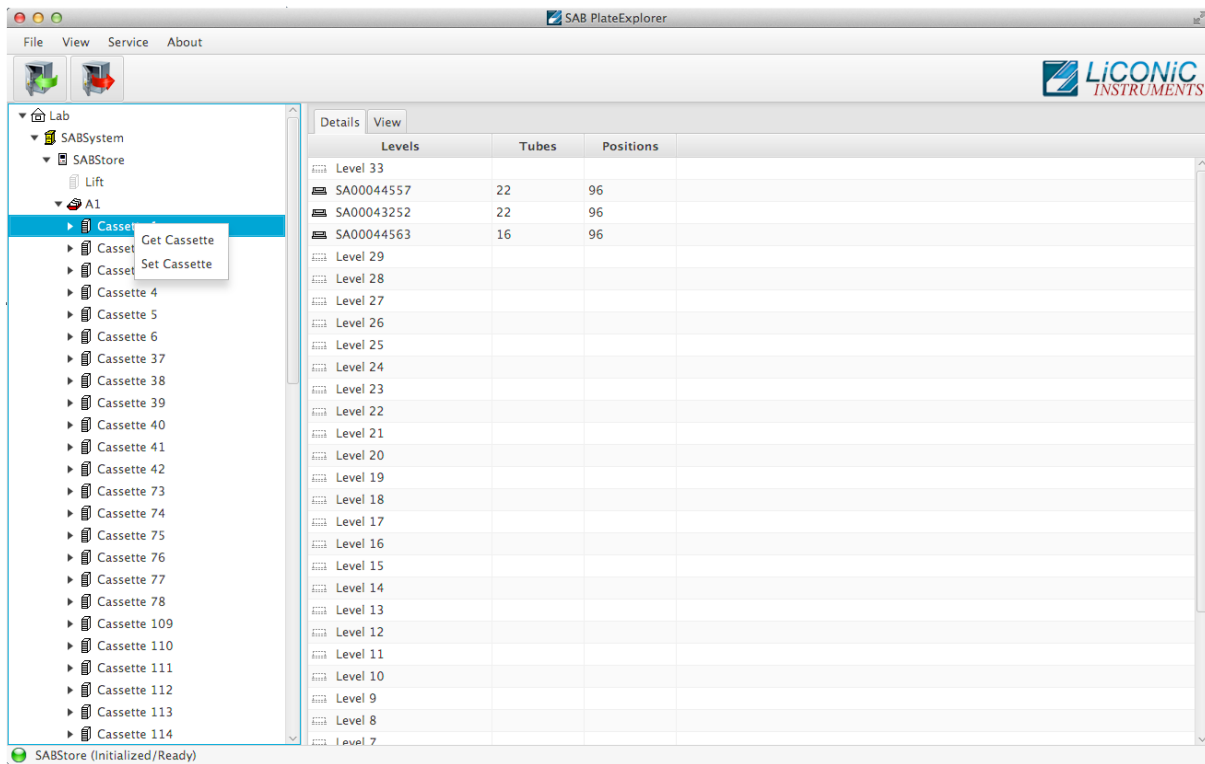

Picture 19: Cassette context menu

18.2.5 Layout of the PlateExplorer

The main window of the PlateExplorer is subdivided into the Menu bar, a quick usage button bar, the contents tree on the left and the detailed information view on the right (see Picture 20). The detailed view on the right can be switched from a “Detail” view showing information of Partition/Cassette/Plate to a more graphical expression “View” (see Picture 21)

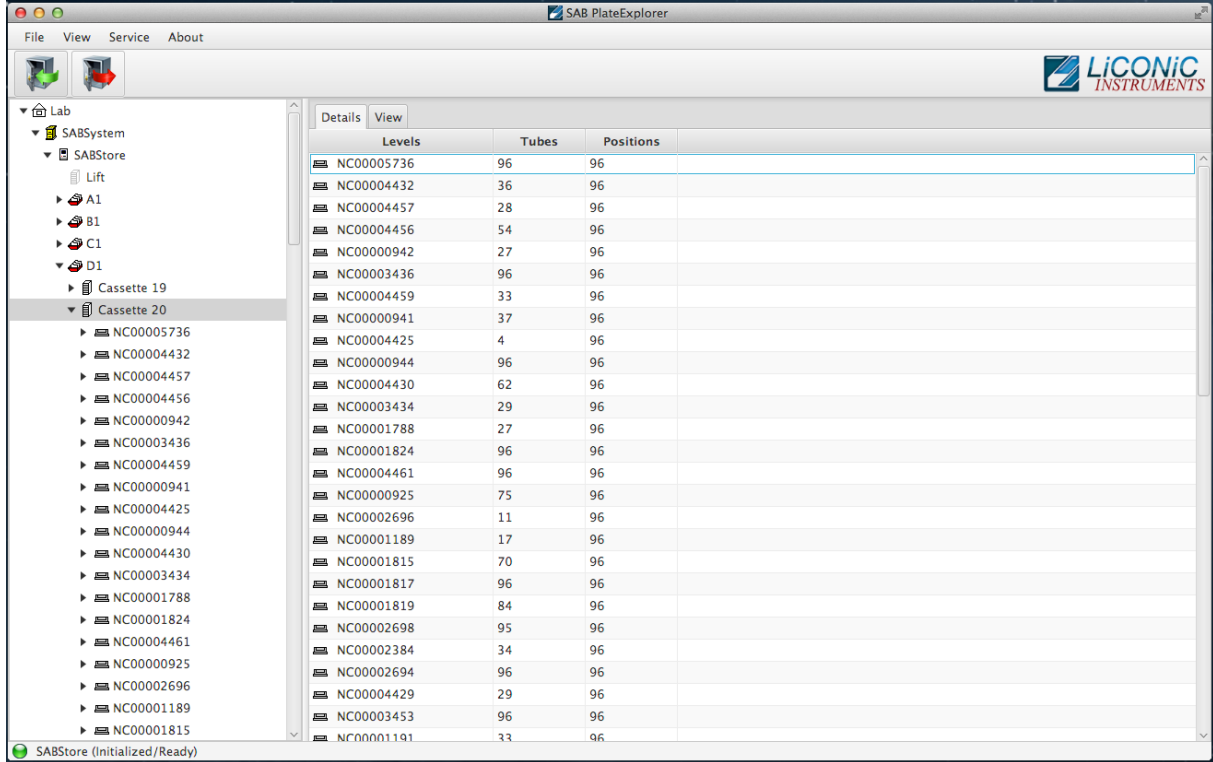

Picture 20: Main screen detailed view of the PlateExplorer

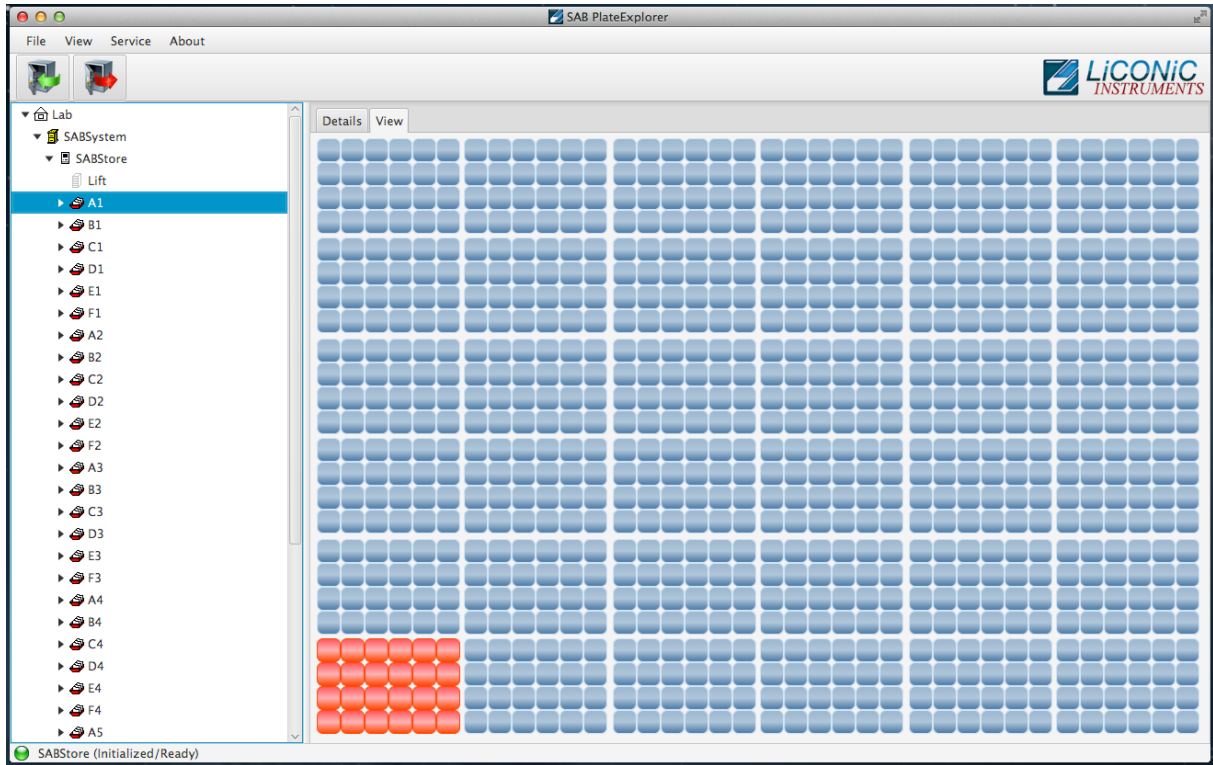

Picture 21: Main screen graphical view of PlateExplorer

Safety Sheets

Safety guides for the work in the service area of the LiCONiC SAB-series

(Ralf Kindle, 27.01.2016 REV 1)

Work on this device should only be performed by Liconic Service Engineers or Service Engineers Certified by Liconic to work on SAB systems.

Works, that require the regulations:

maintenance (repair, maintenance, inspection), cleaning, hardware changes, disturbance removal

Behavior on the machine, that requires the regulations:

lean into the service area, get into / out of the service area, detention at the service area

Work on the device should only start following all given regulations in this document!

Potential danger	Protection mechanism
Contact with dangerous samples	<ul style="list-style-type: none"> • Additional to the usage of thermal protection clothing, please use Nitrile-gloves or gloves with comparable safety properties concerning dangerous materials • Check skin compatibility towards the used disposables
Lacking air condition / lack of oxygen (Measurement value < 20,9%) / too high carbon dioxide levels	<ul style="list-style-type: none"> • Due to very specific local rules and regulations in different countries it is the customers / owners responsibility to install suitable oxygen (O₂) and carbon dioxide (CO₂) monitor systems which trigger alarms to protect the operators around the SAB store. • For works within the area, a breathing mask is recommended (no Cartridge-mask, as this does not help). • Personal oxygen monitors must be worn when entering the service area.
Low temperature skin burn injury / freezing	<ul style="list-style-type: none"> • Only work in thermal protection clothing (thermally protect body, head and hands). Do not touch or pick up anything within the -80°C area without the use of suitable equipment. Never lean into the -80°C area under the isolation or step into it. Generally the work in the service area should be limited to 15 minutes time.

Pressure by mechanical parts	<ul style="list-style-type: none"> • Before entering the service area, switch off the device and put a sign, saying „Do not switch on device!“ on it. After the work a reset and re-initialization is necessary. Attention: Neither the cooling nor the handling should be switched off longer than 30 minutes!
Physical stress due to narrowness of the service area.	<ul style="list-style-type: none"> • Duration of the work within the area should be limited to 15 minutes.
Bodily harm by sharp edges or corners (e.g. air condition pipes)	<ul style="list-style-type: none"> • Overtired or for different reasons unconcentrated persons should not do maintenance work.
Suffocation / burning by indirect contact with LN2	<ul style="list-style-type: none"> • When LN2 has been introduced into the system and the DEWAR needs to be exchanged, wear protective clothing. • In case no exhaust leading the N2 gas out of the room, only enter the room wearing a breathing mask with oxygen supply. • During operation of LN2 backup, do not touch any piping showing frost without protective clothing.
Bodily harm while entering the area by slipping off or falling down	<ul style="list-style-type: none"> • Use suitable equipment for access to service area (save and robust ladder)
Contaminated or destroyed samples or probes by the user (product safety and personnel safety)	<ul style="list-style-type: none"> • To avoid a contamination of or by the samples, no sharp edge tools should be used within the service area.
Sample location / Database integrity	<ul style="list-style-type: none"> • By using barcode readers / scanners and guiding the SAB user Liconic AG is doing utmost to make sure that real sample location matches the stores database but due to the semi - automatic nature of the SAB store the user / customer is finally responsible for sample location by moving them into a particular cassette and associated cassette level manually.

General Rules:

- 1) DO NEVER WORK ALONE WITHIN THE DEVICE. ALWAYS ORGANIZE A SECOND PERSON AS SAFETY GUARD ON THE OUTSIDE OF THE DEVICE THAT IS CONNECTED TO YOU VIA RADIO. FURTHER AN ADMINISTRATIVE PERSON MUST BE REACHABLE IN A SHORT TIME. BOTH MUST BE 100% PHYSICALLY FIT.
- 2) WHILE WORKING IN THE SERVICE AREA, ALWAYS SWITCH ON THE INTEGRATED LAMP. NEVER WORK IN THE DARK.
- 3) FOR ALL KINDS OF WORK, CARRY AN OXYGEN MEASUREMENT DEVICE WITH YOU, HAVING A DISPLAY FOR THE ACTUAL VALUE, AN ADJUSTABLE VALUE FOR THE LIMIT AND AN OPTICAL/ACOUSTIC SIGNAL WHEN THIS LIMIT IS REACHED.

- 4) ENTERING OR WORKING WITHIN THE -80°C AREA OF THE DEVICE IS ALLOWED TO TRAINED LiCONiC PERSONNEL ONLY. THE USER SHOULD NOT WORK WITHIN THIS AREA OR EVEN ENTER IT. OBJECTS FALLEN DOWN OR THINGS TO BE ALIGNED WITHIN THIS AREA SHOULD ONLY BE PICKED UP OR MOVED WITH THE HELP OF PROPER TOOLS.
- 5) IF THERE ARE DOUBTS ABOUT THE FUNCTIONALITY OF THE DEVICE (FATIGUE, ABRASION OR BREAKING OF PARTS), THE USER SHOULD IMMEDIATELY REQUEST SERVICE FROM LiCONiC AND THE USER SHOULD STOP USING THE SYSTEM IMMEDIATELY UNTIL ALL REPAIRED.
- 6) IN CASE OF A FIRE THE DEVICE MUST NOT BE ENTERED UNDER ALL CIRCUMSTANCES.
- 7) EVERY PERSON TAKING PART IN THE WORK ON THE DEVICE SHOULD BE INFORMED ABOUT THE SAFETY REGULATIONS BEFORE STARTING TO WORK. ONCE A YEAR AN ACTIVITY PLANNING SHOULD BE MADE WITH ALL PARTICIPATING PERSONS.